

Efficient Sampling of Atmospheric Methane for Radiocarbon Analysis and Quantification of Fossil Methane

Giulia Zazzeri,* Xiaomei Xu, and Heather Graven

Cite This: *Environ. Sci. Technol.* 2021, 55, 8535–8541

Read Online

ACCESS |

Metrics & More

Article Recommendations

Supporting Information

ABSTRACT: Radiocarbon (^{14}C) measurements offer a unique investigative tool to study methane emissions by identifying fossil-fuel methane in air. Fossil-fuel methane is devoid of ^{14}C and, when emitted to the atmosphere, causes a strong decrease in the ratio of radiocarbon to total carbon in methane ($\Delta^{14}\text{CH}_4$). By observing the changes in $\Delta^{14}\text{CH}_4$, the fossil fraction of methane emissions can be quantified. Presently, there are very few published $\Delta^{14}\text{CH}_4$ measurements, mainly because it is challenging to collect and process the large volumes of air needed for radiocarbon measurements. We present a new sampling system that collects enough methane carbon for high precision $\Delta^{14}\text{CH}_4$ measurements without having to transport large volumes of air. The system catalytically combusts CH_4 into CO_2 and adsorbs the combustion-derived CO_2 onto a molecular sieve trap, after first removing CO_2 , CO , and H_2O . Tests using reference air show a $\Delta^{14}\text{CH}_4$ measurement repeatability of 5.4%, similar or better than the precision in the most recent reported measurements. We use the system to produce the first $\Delta^{14}\text{CH}_4$ measurements in central London and show that day-to-day differences in $\Delta^{14}\text{CH}_4$ in these samples can be attributed to fossil methane input. The new system could be deployed in a range of settings to investigate CH_4 sources.

KEYWORDS: radiocarbon, atmospheric methane, methane emissions, molecular sieve, fossil fraction

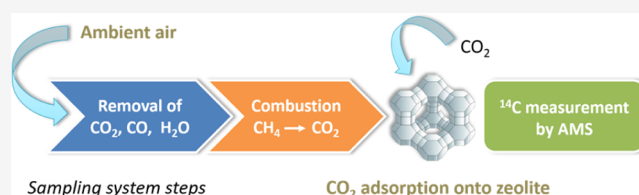

1. INTRODUCTION

To mitigate the effects of climate change, governments are setting ambitious targets for reducing greenhouse gas emissions that require careful tracking of emissions. However, emissions of methane (CH_4), the second most important anthropogenic greenhouse gas, have large uncertainties and there is no consensus on the cause of the strong variability in the atmospheric growth rate of CH_4 observed recently.¹

Atmospheric measurements of methane stable isotopes² and methane co-emitted compounds (e.g., ethane)³ have been used as tracers of different methane sources. However, stable isotopic signatures and methane/ethane emission ratios of individual sources often span large ranges, showing the need for additional constraints on CH_4 emissions.

Radiocarbon (^{14}C) measurements are a powerful tracer of fossil fuel emissions because fossil carbon has lost all its ^{14}C after millions of years of radioactive decay during burial underground. When fossil-derived CH_4 is emitted into the atmosphere, it causes a strong decrease in the radiocarbon content ($\Delta^{14}\text{CH}_4$). Studies based on $\Delta^{14}\text{CH}_4$ measurements provide the best constraint on the fossil fraction of global methane emissions,^{4–7} with the most recent estimates around 30%.^{7,8} However, $\Delta^{14}\text{CH}_4$ measurements have not yet been applied to quantify regional fossil fractions. One study⁹ measured radiocarbon in six samples collected in Los Angeles, USA, but it did not provide a quantitative analysis of the fossil fraction due to the relatively large ^{14}C variability in background

samples. Observations of $\Delta^{14}\text{CH}_4$ would be particularly useful for evaluating the source partitioning of methane emissions in urban areas or other regions of mixed sources that show discrepancies in existing estimates of the fossil fraction.¹⁰

Despite their usefulness, presently, there are very few published measurements of atmospheric $\Delta^{14}\text{CH}_4$. Measurements on a regular basis are currently conducted at Utqiagvik, Alaska, and at Baring Head, New Zealand. However, only a few measurements for the Utqiagvik site are published,¹¹ and the Baring Head measurements after 2000 have not been published yet (ref 7; K. Lassey, personal communication). The lack of $\Delta^{14}\text{CH}_4$ observations is mainly due to challenges in the sampling and processing of large volumes of air needed to obtain enough CH_4 for ^{14}C analysis. Another challenge lies in assessing the influence of ^{14}C emissions from nuclear power plants on the $\Delta^{14}\text{CH}_4$ observations. In particular, ^{14}C emitted by pressurized water reactors (PWRs), the most common nuclear reactor type in use today, is primarily in the form of CH_4 , in contrast to other reactor types that emit ^{14}C in the form of CO_2 .¹² Due to the nuclear power industry, the current

Received: May 22, 2020

Revised: May 14, 2021

Accepted: May 14, 2021

Published: June 8, 2021



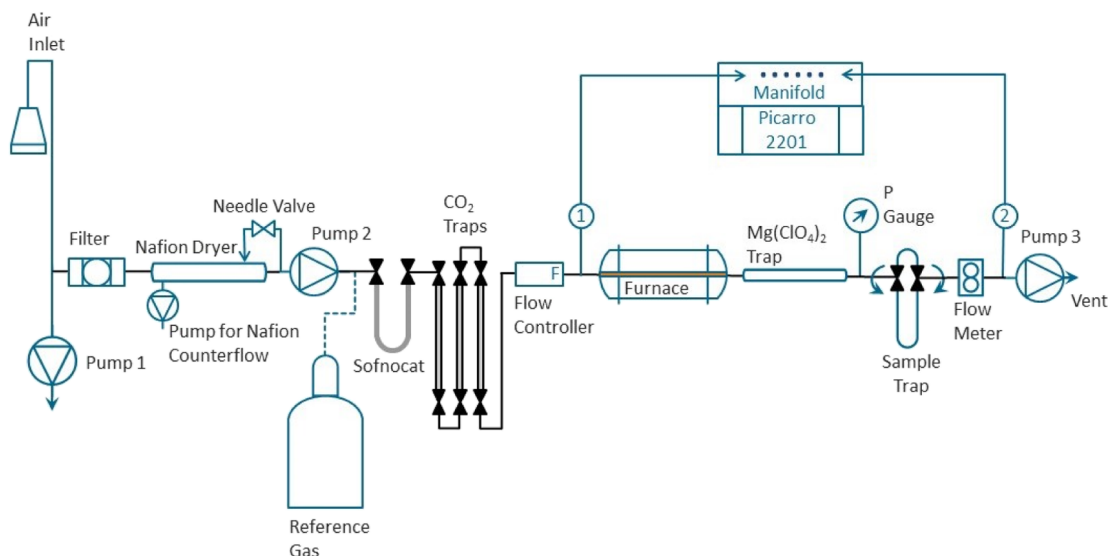

Figure 1. Diagram of the sampling system.

atmospheric $\Delta^{14}\text{CH}_4$ value is probably near 350‰,^{9,11,13} compared to the $\Delta^{14}\text{CO}_2$ value near 0‰.¹⁴

To sample atmospheric CH_4 for ^{14}C measurements, large volumes of air have been collected either by pressurization into cylinders using strong pumps^{9,15} or by collection into large bags.¹⁶ Methane must then be isolated in the laboratory by cryogenics, chemical traps, or gas chromatography. The CH_4 is combusted to CO_2 and graphitized for ^{14}C measurements by accelerator mass spectrometry (AMS). Other sampling systems have been tested for specific research applications for CH_4 from wetlands or permafrost,^{17,18} for CH_4 dissolved in marine and freshwaters¹⁹ and for CH_4 dissolved in ancient air extracted from glacial ice.²⁰ The latest $\Delta^{14}\text{CH}_4$ measurements of atmospheric methane are reported with uncertainties of 12‰¹⁶ and 5–11‰.⁹ The measurement precision tends to be limited by the sample size, as it is challenging to collect enough methane carbon for high precision measurements.

In this study, we present a unique sampling system for atmospheric CH_4 at ambient concentrations (~ 2 ppm) that enables efficient collection of enough carbon for high precision $\Delta^{14}\text{C}$ measurements (0.15–0.3 mgC) without the need for pressurization or cryogenic extraction. Our sampling procedure separates the methane carbon from air during sampling, reducing the need for sample processing at the radiocarbon laboratory and associated costs. We demonstrate the reproducibility of the system by measuring samples collected from a reference air cylinder, and we use the system to make the first radiocarbon measurements in atmospheric methane in central London.

2. MATERIALS AND METHODS

Our sampling system is based on the use of a molecular sieve material (zeolite), which has a porous structure that adsorbs CO_2 molecules. The high affinity of molecular sieves to CO_2 allows for separation of CO_2 from air and efficient trapping of CO_2 into a relatively small amount of molecular sieve grains packed in a small volume.²¹ Molecular sieve cartridges have been utilized in many studies, in particular for collection of soil-respired CO_2 , but also for atmospheric and aquatic CO_2 .^{22–25} The sampled CO_2 is desorbed by heating and sample traps can then be reused.

Our sampling system consists of three main steps: first H_2O , CO_2 , and CO are removed from the target air, then CH_4 is catalytically combusted into CO_2 , and finally the combustion-derived CO_2 is adsorbed onto a molecular sieve trap.

The following sections describe the sampling system and the methods for testing the system efficiency, sample blank (contamination), and overall precision. To demonstrate the use of the system in ambient air, atmospheric methane was sampled in central London by drawing air from an air intake placed on the roof of a ~ 25 m building at the Imperial College London, South Kensington. Measurements of $\Delta^{14}\text{C}$ in all samples were conducted by the AMS at the Keck–Carbon Cycle Accelerator Mass Spectrometer (Keck-CCAMS) facility at the University of California, Irvine (UCI).

2.1. Sampling System Setup. When sampling ambient air from the rooftop mast, the system is used as shown in Figure 1, with the air flowing from left to right through the solid lines. A pump (30 lpm KNF LABOPORT pump) is used to flush the air line connecting the inlet on the roof to the laboratory (pump 1). A 5 lpm KNF pump (pump 3) draws the air through the system. The sample air water content is reduced to a value of $\sim 0.1\%$ via a nafion drier (Permapure PD-model), using the split sample method (Figure 1). The system before the flow controller is pressurized to ~ 40 psia using a 5 lpm pump placed after the nafion dryer (pump 2) to allow for sampling at a flow rate of 300 cc/min. When sampling a reference gas, the air flows directly into the system through the dashed line in the lower left, bypassing the drying and pressurization stage.

Atmospheric CO_2 and CO are first removed from the sample air. CO is removed using 50 g of Sofnocat placed in a stainless steel tube. CO_2 and remaining H_2O are removed by three traps, each with 20 g of $13\times$ molecular sieve pellets (Merck 1.0 nm beads) placed in linear 17" stainless steel tubes. An Alicat flow meter (MC-1 SLPM-D/5M) is used to control the flow rate. The air, now void of CO and CO_2 , enters a customized furnace (Omega Furnaces, 9" length), which catalytically combusts CH_4 into CO_2 . Complete combustion of CH_4 is achieved at 750 °C, determined experimentally, using a 3/8" quartz tube with ~ 1 g of platinumized quartz wool (Shimadzu Scientific Instruments, USA) as catalyst.²⁰ The

water derived from combustion is adsorbed into a 20 g magnesium perchlorate trap. During sampling, CO₂, CH₄, and H₂O concentrations in the flow are monitored periodically on a Picarro G2201-i analyzer, which measures CO₂, CH₄, and H₂O concentrations and $\delta^{13}\text{C}_{\text{CH}_4}$ and $\delta^{13}\text{C}_{\text{CO}_2}$ at two points. At (1), to check for complete adsorption of H₂O and CO₂ prior to combustion and at (2), to check for complete CH₄ combustion and combustion-derived CO₂ trapping. A valve manifold is used to switch the Picarro valves during the sampling.

2.2. Sample Trap Design. The sample trap has been designed to accommodate 1 g of 13× molecular sieves (Sigma-Aldrich 45–60 mesh) in the bottom of a U-shaped stainless steel tube of 24" length and 1/4" OD diameter (part 1 in Figure 2). The trap is similar to the one used in soil respiration

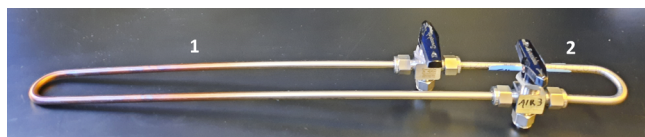

Figure 2. Molecular sieve trap with two three-way valves. Part 1 holds the molecular sieve in the bottom secured by quartz wool. Part 2 is a bypass to flush the system prior to sampling.

studies,²⁴ which makes it easy to be used with the existing equipment in the UCI laboratory. Two three-way valves connect this part to a smaller, empty U-shaped stainless steel tube (part 2 in Figure 2). By switching the valves, we can direct the flow into 1 (trap) or 2 (bypass tube). When the air is directed into 2, the whole system can be flushed with sample air before starting combustion, while keeping the trap connected to the sampling line. Then, sample air can be directed into 1 when starting the collection of a CH₄-derived CO₂ sample.

2.3. Pretreatment Procedure. The pretreatment procedure for the 13× molecular sieve material used in the sample trap consists of three steps. The first step is a preliminary desorption of CO₂, H₂O, and any other gases where the molecular sieves are conditioned at 700 °C in open air for at least 3 h. Second, the 13× material is placed inside the stainless steel trap and it is heated while flushing with ultra high purity (UHP) nitrogen gas. Traps are heated at temperatures ranging from 250 to 650 °C for approximately 2 h while flushing with UHP nitrogen, until all adsorbed gases including CO₂ are completely removed, in a manner similar to the pretreatment procedure reported by Palonen et al. (2017).¹⁸ The CO₂ desorption at different temperatures is shown in Figure S1. Third, before sampling, the trap is flushed with laboratory air and then heated at 550 °C while flushing with UHP nitrogen. We added this last step to the pretreatment procedure as we observed that traps that adsorbed CO₂ and were recharged showed a lower blank. If the molecular sieve trap has already been used to collect and desorb a sample, it is recharged by heating at 550 °C with UHP nitrogen flushing for at least 2 h.

2.4. Collection of CH₄-Derived CO₂ Samples. Before sampling, we leak-check the system by flushing it with UHP nitrogen gas while ensuring that the CO₂ and CH₄ concentrations within the system are zero when measured on the Picarro at point 2 and, therefore, there is no contamination of laboratory air in the system. Then, we turn on the furnace at 750 °C and, keeping the two 3-way valves of the sample trap switched to 2, we flush the system with the sample air to check

for full trapping of CO₂ upstream of the combustion furnace (1 in Figure 1) and for complete combustion (2 in Figure 1). To start sampling, both three-way valves of the sample trap are switched to the direction of the trap (1 in Figure 2). The system operates with continuous flow at a rate of ~300 cc/min and requires approximately 10 h to sample 180 L of air and obtain 0.15 to 0.2 mg C from atmospheric CH₄. Once the sample is collected, the sample trap can be sent directly to the radiocarbon laboratory.

2.5. ¹⁴C Analysis. The trapped CO₂ samples are shipped to the Keck-CCAMS facility at the University of California, Irvine. CO₂ is released by heating the sample trap at temperatures ranging from 400 to 450 °C for 20 min, which has been tested to be the optimum temperature and time for CO₂ extraction. CO₂ is then cryogenically purified from any trapped water and noncondensable gases and graphitized through the sealed tube zinc reduction method.²⁶ After purification, if the sample yields (amount of carbon retrieved from the sample trap) are >0.2 mg C, a small aliquot is taken for $\delta^{13}\text{C}$ analysis via isotope ratio mass spectrometry (GasBench II, coupled with DeltaPlus XL, Thermo Fisher Scientific, Pittsburgh, PA, USA). The graphite sample is analyzed using 500 kV AMS. Graphite analysis is used instead of direct CO₂ analysis because it enables higher precision radiocarbon measurements for small samples (2‰ against >7‰ for modern samples).²⁷ Background corrections are applied following the method reported by Santos et al. (2007).²⁸ The extraneous carbon contamination from sampling was quantified from the measurements of the ¹⁴C/C ratio and the amount of C extracted from tests assessing the processing blank (Section 3 below). Results are provided in Δ notation, which accounts for isotopic fractionation and sample age corrections according to Stuiver and Polach (1977).²⁹ The reported uncertainty for individual samples includes the error from counting statistics (i.e., the square root of the sum of the ¹⁴C counts), variation of the primary standard OX-I and background uncertainty.

2.6. Reference Material. We use two reference materials of the atmospheric CH₄ concentration level in pressurized cylinders to test the system. The first reference M1 is a synthetic mixture of 2 ppm methane in zero air (BOC) in a 50 L cylinder at 150 bar. This cylinder contains no CO₂, and it has been used to test the combustion efficiency and the trapping of the CH₄-derived CO₂. It is also used to assess the amount of contamination during sampling (processing blank), assuming the CH₄ in the cylinder is entirely fossil in origin, that is, ¹⁴C-free. The second reference R1 is ambient air in a 50 L cylinder filled at the University of East Anglia in May 2018. It has CH₄ and CO₂ concentrations of 2023 ppb and 406 ppm, respectively, and a $\delta^{13}\text{C}$ of $-48.3 \pm 0.3\text{‰}$ for CH₄ and $-8.6 \pm 0.1\text{‰}$ for CO₂, measured on the Picarro analyzer. The R1 cylinder is used to test the precision of the system by enabling repeated measurements of the same reference air.

2.7. Testing Strategy. We performed five tests to evaluate the system performance and $\Delta^{14}\text{C}_{\text{CH}_4}$ measurement reproducibility.

2.7.1. Test 1: Evaluation of the Processing Blank. Seven samples ("blanks") were prepared to assess the contamination of the sample traps either from the molecular sieve material itself or from the sampling line. Three blanks (BL1-2-5) were prepared by filling the sample traps with UHP nitrogen directly after the pretreatment. The other four blanks (BL 3-4-6-7) were prepared by flushing the entire sampling system with

reference air (R1) but without combusting the CH₄, for at least 10 h at a flow rate of 300 cc/min. In both cases, it is expected that the CO₂-scrubbed air or nitrogen would be analogous to real samples and the amount of CO₂ recovered from the trap provides a measure of the system contamination.

To fully reproduce the sampling procedure, including CH₄ combustion, the processing blank was alternately evaluated by collecting five CH₄ samples of 0.1–0.2 mgC using the zero air with methane cylinder M1. As the CH₄ in the cylinder is assumed to be ¹⁴C-free, the deviation of the measured $\Delta^{14}\text{C}$ from the value of -1000% , weighted by the amount of carbon collected, will give the total amount of modern carbon introduced during sampling. This test also evaluates the efficiency of the CH₄ combustion and CH₄-derived CO₂ trapping.

2.7.2. Test 2: Evaluation of CO Trapping. One sample has been collected to evaluate the CO trapping by the Sofnocat trap. The system was run for 10 h using the reference air cylinder R1 and a combustion temperature of 450 °C in order to oxidize only CO and not CH₄, following the study by Sparrow and Kessler (2017).¹⁹ The CO trapping efficiency has been assessed by comparing the yield and $\Delta^{14}\text{C}$ of this sample to the blanks.

2.7.3. Test 3: Reproducibility of CO₂ Trapping Only. Four replicate samples were collected by flushing the sample trap at 100 cc/min for 15 and 25 min with the reference air cylinder R1 to collect samples of approx. size of 0.3 and 0.5 mgC, respectively. In this test, to sample CO₂ from R1, the reference air was introduced directly upstream of the sample traps, bypassing the CO and CO₂ trapping. This is a basic test to demonstrate how reproducible $\Delta^{14}\text{C}$ measurements of trapped CO₂ are when the sample size is in the range of 0.2–0.5 mg of C. This tests the efficiency of the pretreatment procedure of the molecular sieves, whether the amount of molecular sieve in the sample trap is sufficient, and the reproducibility of $\Delta^{14}\text{C}$ achievable without any potential effects from the CO₂ and CO trapping or the combustion, or from the long sampling time.

2.7.4. Test 4: Reproducibility of the Entire System Using Reference R1. Five replicate CH₄ samples of approximate size of 0.1–0.2 mg C were collected using reference air R1. This test was performed to verify complete CO₂ scrubbing prior to combustion and the measurement reproducibility of CH₄-derived trapped CO₂, when CO₂ is at ambient concentrations in the source air.

2.7.5. Test 5: Memory Test. To check that the sample is not influenced by the previous sample run through the system, we alternated runs of ¹⁴C-depleted gas to modern samples. Two sample traps used in test 1 have been used to collect CO₂ samples from outside air.

2.7.6. Test 6: Measurements of $\Delta^{14}\text{C}$ in CH₄ in Ambient Air. To demonstrate the use of the system with ambient air, two samples of approximately 0.1 and 0.15 mg C size were collected by drawing outside air from the roof mast (Figure 1). Samples were collected on the 7th and 18th of March 2020, from 1 to 11 pm and from 12 to 10 pm, respectively. The sampling time was chosen in order to primarily sample well mixed air during the day.

3. RESULTS AND DISCUSSION

3.1. Test 1: Evaluation of the Processing Blank.

Following the pretreatment and desorption procedure described in previous sections, the amount of CO₂ retrieved from six blank samples (BL1, BL3-4-5-6-7) is between 1 and 2

μg of C. Blanks of this size are typical at the Keck-CCAMS facility.²⁷ BL2 shows a significantly higher value (33.6 μg). BL1, BL2, BL3, and BL4 have been combined for graphitization and analyzed. BL1 and BL2 show a $\Delta^{14}\text{C}$ value of $-15.6 \pm 45.8\%$, similar to atmospheric CO₂ levels, indicating that there was some atmospheric CO₂ contamination in BL2, potentially from a small leak in the sample trap fittings or from some CO₂ left in the molecular sieves. A $\Delta^{14}\text{C}$ value of $161.3 \pm 74.9\%$ has been measured from BL3 and BL4. BL5, BL6, and BL7 show values of 117.8 ± 33.3 , -68.6 ± 32.7 , and $-89.6 \pm 20.2\%$, respectively. These results indicate that the background is from modern carbon and the effect on the CH₄ samples is small. The relatively low background of BL3-4-6-7 shows that CO₂ at ambient concentrations is effectively removed by the CO₂ traps throughout the entire sampling time (see Figure S3). BL2 shows that there is a danger of small leaks in the sample traps. Thus, careful leak checking and periodic processing blank testing has been implemented.

The $\Delta^{14}\text{C}$ values of samples from reference M1 in Table 1 indicate a modern extraneous carbon contamination amount of

Table 1. Measured $\Delta^{14}\text{C}$ of CH₄ Combustion-Derived CO₂ from Reference M1 and Corresponding Yields in mgC^a

UCIAMS#	ID	$\Delta^{14}\text{C}$ (‰)	±	yield (mgC)	calculated blank size (mg)
218851	A1	-965.9	0.3	0.18	0.0061
218852	A2	-980.2	0.2	0.20	0.0040
218853	A3	-976.2	0.3	0.26	0.0062
242492	A4	-934.2	0.4	0.09	0.0062
242493	A5	-958.2	0.4	0.12	0.0051
				mean	0.0055
				St dev	0.0010

^aDifferences in yields are due to differences in sampling time.

$5.5 \pm 1.0 \mu\text{g}$, higher than the amount of carbon extracted from the previous six samples. This suggests that some additional carbon might originate from the combustion process. However, we note that the contaminant masses do not scale with the sample masses, as expected if the extra contaminant is being produced as a result of hot furnace interactions. Therefore, further tests will be carried out to verify such interactions.

For the samples collected in this work, we estimate that the contaminant carbon is modern based on the blank test results, and we apply an averaged processing blank size value of $5.5 \pm 1.0 \mu\text{g}$ and a $\Delta^{14}\text{C}$ value of $0 \pm 50\%$ (based on the atmospheric $\Delta^{14}\text{C}$ range we have measured in London). The uncertainties of the processing blank are propagated into the final uncertainties as well. With these considerations, a sample larger than 0.15 mgC should be collected to reduce the single measurement uncertainty lower than 5%.

Other possible scenarios have been explored: (a) the contaminant carbon is intermediate between modern and fossil and has a value of -500% ; (b) the contaminant carbon has a value of 350% (characteristic of atmospheric methane). In case (a), the blank size would be higher, $11 \pm 2 \mu\text{g}$, leading to two times higher single measurement uncertainty. In case (b), the blank size is reduced to $4 \pm 0.7 \mu\text{g}$, and also the single measurement uncertainty of methane samples is slightly smaller.

The amount of carbon collected is 65–90% of that expected, indicating that the collection is not entirely complete, potentially due to incomplete combustion. Although a higher combustion efficiency would decrease the sampling time, complete combustion is not necessary, as long as the required amount of CH₄ combustion-derived CO₂ is collected. Tests of increasing the combustion temperature did not increase the amount of carbon collected, but other changes might increase the combustion efficiency and therefore reduce the sampling time.

3.2. Test 2: Evaluation of CO Trapping. The sample collected contains 0.006 mgC and has a $\Delta^{14}\text{C}$ value of $3 \pm 43\%$, which are comparable to the blank values based on the M1 samples. Therefore, we conclude that there is no contamination of the system from atmospheric CO and the Sofnocat trap is efficient in trapping CO for 10 h of sampling.

3.3. Test 3: Reproducibility of CO₂ Trapping Only. The CO₂ samples collected using R1 show an average $\Delta^{14}\text{C}$ value of -4.3% and standard deviation of 1.6% (Table 2). These

Table 2. Measured $\Delta^{14}\text{C}$ of CO₂ and $\delta^{13}\text{C}$ from Reference R1 with the Corresponding Yields in mgC^a

UCIAMS#	ID	$\delta^{13}\text{C}$ (‰)	±	$\Delta^{14}\text{C}$ (‰)	±	yield mgC
218164	T3-M4	-9.1	0.15	-1.9	1.7	0.32
218165	T3-M5	-8.9	0.15	-4.0	1.7	0.32
218166	T3-M6	-8.7	0.15	-4.2	1.8	0.57
218168	T3-M8	-9.2	0.15	-5.3	1.7	0.33
218169	T3-M9	-8.8	0.15	-6.2	1.7	0.62
	mean	-8.9		-4.3		
	St dev	0.2		1.6		

^aA background of $1.5 \mu\text{C}$ and 0% has been used to correct these values, as these samples were collected without combustion.

results are consistent with the $\Delta^{14}\text{C}$ expected for atmospheric CO₂, which may contain some CO₂ from regional fossil fuel combustion. From these samples, a small aliquot was taken for $\delta^{13}\text{C}$ analysis. A $\delta^{13}\text{C}$ mean value of $-8.9 \pm 0.2\%$ (Table 2) shows good measurement repeatability and is in good agreement with the R1 $\delta^{13}\text{C}$ of $-8.6 \pm 0.1\%$ measured by the Picarro, indicating complete collection efficiency. The amounts of carbon collected are also as expected, indicating 95–100% collection efficiency. These measurements demonstrate that the sample traps are suitable for collection of CO₂ in amounts of 0.3–0.6 mgC and the measured $\Delta^{14}\text{C}$ and $\delta^{13}\text{C}$ are highly reproducible.

3.4. Test 4: Reproducibility of the Entire System Using Reference R1. The $\Delta^{14}\text{C}$ values of the sampled CH₄-derived CO₂ from reference R1 are consistent, with a mean value of 502.0% and standard deviation of 5.4% (Table 3). The mean $\delta^{13}\text{C}$ value of $-47.9 \pm 0.6\%$ shows good agreement with the known $\delta^{13}\text{C}$ value of $-48.3 \pm 0.3\%$ for R1. Yields are 60–90%, similar to Test 1. The repeatability of 5.4% is similar to or better than the reported precision of the most recent observations from Espic et al. (2019) (12%)¹⁶ and Townsend-Small et al. (2012) (± 5 to 11%)⁹. We note that the uncertainties reported by Townsend-Small et al. (2012) are the individual measurement uncertainty and not the standard deviation of repeated measurements of reference air, as we report, which can be higher.

If we apply a blank of $11 \pm 2 \mu\text{g}$ with a $\Delta^{14}\text{C}$ value of -500% (case a in Section 3.1), the overall uncertainty would

Table 3. Values of $\Delta^{14}\text{C}$ of CH₄ Combustion-Derived CO₂ from Reference R1 and Corresponding Yields in mgC^a

UCIAMS#	ID	$\delta^{13}\text{C}$ (‰)	±	$\Delta^{14}\text{C}$ (‰)	±	yield (mgC)
225028	T4-M6	-47.2	0.15	509.6	6.7	0.12
225029	T4-M8	-48.2	0.15	495.9	5.0	0.16
225030	T4-M9	-48.1	0.15	502.7	4.9	0.16
237522	T4-D5*			503.9	7.9	0.10
235682	T4-D6*			497.8	8.2	0.09
	mean	-47.9		502.0		
	St dev	0.6		5.4		

^aDifferences in the yield (amount of carbon collected) are due to different sampling times. *The $\delta^{13}\text{C}$ of these samples was not analyzed due to the relatively small sample size.

be 22.6% , while if we apply a blank of $4 \pm 0.7 \mu\text{g}$ and a value of 350% (case b in Section 3.1), the overall uncertainty would be 6.7% . We note that the $\delta^{13}\text{C}$ data for the R1 samples are more consistent with a smaller blank from atmospheric CO₂ or CH₄ than a larger blank with fossil carbon. We also note that there is no correlation between the $\Delta^{14}\text{C}$ values of R1 and the sample sizes: a large fossil carbon contamination (case a) would have led to much lower $\Delta^{14}\text{C}$ values for T4-D5 and T4-D6 due to their relatively small size. These results show that the processing blank needs to be further characterized, and more tests will be carried out to better evaluate the contaminant carbon.

The repeatability of measurements could be further improved by reducing the modern background effect. This can be achieved by collecting larger samples, running the system for a time longer than 10 h. However, shorter sampling times would be more desirable and will be tested in future works.

The measured $\Delta^{14}\text{C}$ value is higher than expected from previous studies that suggest atmospheric values should be near 350% .^{9,11,13} Back trajectories using the Hysplit model^{30,31} (Figure S4) showed that winds were easterly during the day when the R1 cylinder was filled in Norwich (31st May 2018). ¹⁴C emissions from Sizewell B, a PWR site 40 km southeast of Norwich, or from European PWRs are likely to explain the large $\Delta^{14}\text{C}$ enhancement, demonstrating how the impact of nuclear power plant emissions must be carefully assessed when applying $\Delta^{14}\text{CH}_4$ measurements for regional studies.^{14,15,32}

3.5. Test 5: Memory Test. Sample traps A1 and A3 which were used in Test 1 for samples of ¹⁴C-free CH₄ were subsequently used to collect atmospheric CO₂ from outside air after being recharged at $550 \text{ }^\circ\text{C}$. They show $\Delta^{14}\text{C}$ values of -42.2 ± 1.4 and $-46.2 \pm 1.8\%$, which are consistent with $\Delta^{14}\text{CO}_2$ values we observed in central London in summer 2020 and that have been observed in other big conurbations.³³ This proves that traps can be recharged and reused without a significant influence from the previous collected sample.

3.6. Test 6: Measurements of $\Delta^{14}\text{C}$ in CH₄ in Ambient Air. Atmospheric samples collected on March 7th and 18th 2020 from the rooftop inlet at Imperial College in central London show values of 330.7 and 302.2% , respectively (Table 4). The lower sample size for the sample on 7th March is due to the partial displacement of molecular sieves from the bottom of the trap during the sampling and a partial extraction of the sampled combustion-derived CO₂ for graphitization.

Table 4. Measurements $\Delta^{14}\text{C}$ of Atmospheric CH_4 -Derived CO_2 Samples from Imperial College^a

UCIAMS#	collection date	ID	$\Delta^{14}\text{C}$ (‰)	±	yield (mgC)	average CH_4 conc. (ppb)	average wind speed (m/s)
230513	March 07/2020	Air-M9	330.7	6.9	0.09	1960	3.7
230516	March 18/2020	Air-1	302.2	4.1	0.15	1992	2.8

^aAverage CH_4 concentration and wind speed during the period of sampling.

The amount of carbon in the sample on 18th March was 88% of that expected.

The measured $\Delta^{14}\text{C}$ values are lower than the estimated background value of approx. 350‰, as expected in urban areas where CH_4 emissions will lower the $\Delta^{14}\text{C}$.¹⁰ Air trajectories (Figure S5) indicate that air was originating from the Atlantic Ocean and measurements were unlikely to be influenced by ^{14}C emissions from Sizewell B or European PWRs. On March 18th, the average methane concentration during the sampling period was 32 ppb higher than on March 7th and average wind speed was slower (see Table 4), which is consistent with a larger build-up of CH_4 emissions and a lower $\Delta^{14}\text{C}$ value. The decrease in $\Delta^{14}\text{C}$ between the two samples is larger than 7‰ per 10 ppb CH_4 , which is consistent with a purely fossil CH_4 source¹⁰ if we assume that the upwind air composition and any influence of nuclear power plants are the same for both samples. The CH_4 emission attribution to fossil sources supports previous studies of methane sources in central London, which found that leaks from the natural gas distribution network are a major methane source and are likely to be underestimated by bottom-up inventories.^{34,35}

These samples demonstrate how measuring $\Delta^{14}\text{CH}_4$ in environments where methane sources are juxtaposed and poorly constrained could improve the source partitioning of emissions in these areas. The system we have developed allows for high precision measurements to be made by separating methane carbon at the point of sampling, thus eliminating the need for transporting and processing large volumes of air.

At present, the system is a laboratory prototype, and we demonstrated its suitability for local or regional $^{14}\text{CH}_4$ studies, where comparative measurements are made of upwind and downwind air masses. In order to use the system for global $^{14}\text{CH}_4$ budget studies and better assess the measurement uncertainty and accuracy, the system blank will be further characterized and the system will be compared with established methods.

■ ASSOCIATED CONTENT

SI Supporting Information

The Supporting Information is available free of charge at <https://pubs.acs.org/doi/10.1021/acs.est.0c03300>.

CO_2 and H_2O desorption during the sample trap pretreatment, CO_2 and H_2O desorption during the recharging of the CO_2 traps, the Picarro readings at point 1 throughout the sampling, and back-trajectories for sampling dates of the R1 cylinder in Norwich and the atmospheric samples in London (PDF)

■ AUTHOR INFORMATION

Corresponding Author

Giulia Zazzeri – Physics Department, Imperial College London, London SW7 2AZ, U.K.; orcid.org/0000-0002-7297-5670; Email: g.zazzeri@imperial.ac.uk

Authors

Xiaomei Xu – Department of Earth System Science, University of California, Irvine, Irvine, California 92697-3100, United States

Heather Graven – Physics Department, Imperial College London, London SW7 2AZ, U.K.

Complete contact information is available at: <https://pubs.acs.org/10.1021/acs.est.0c03300>

Notes

The authors declare no competing financial interest.

■ ACKNOWLEDGMENTS

This project has received funding from the European Research Council (ERC) under the European Union's Horizon 2020 research and innovation programme (grant agreement 679103). We thank Andrew Manning for filling the reference air cylinder at UEA Norwich, and Ryo Fujita for his help in the laboratory.

■ REFERENCES

- (1) Nisbet, E. G.; Manning, M. R.; Dlugokencky, E. J.; Fisher, R. E.; Lowry, D.; Michel, S. E.; Myhre, C. L.; Platt, S. M.; Allen, G.; Bousquet, P.; Brownlow, R.; Cain, M.; France, J. L.; Hermansen, O.; Hossaini, R.; Jones, A. E.; Levin, I.; Manning, A. C.; Myhre, G.; Pyle, J. A.; Vaughn, B. H.; Warwick, N. J.; White, J. W. C. Very Strong Atmospheric Methane Growth in the 4 Years 2014–2017: Implications for the Paris Agreement. *Global Biogeochem. Cycles* **2019**, *33*, 318–342.
- (2) Zazzeri, G.; Lowry, D.; Fisher, R. E.; France, J. L.; Lanoisellé, M.; Nisbet, E. G. Plume mapping and isotopic characterisation of anthropogenic methane sources. *Atmos. Environ.* **2015**, *110*, 151–162.
- (3) Aydin, M.; Verhulst, K. R.; Saltzman, E. S.; Battle, M. O.; Montzka, S. A.; Blake, D. R.; Tang, Q.; Prather, M. J. Recent decreases in fossil-fuel emissions of ethane and methane derived from firn air. *Nature* **2011**, *476*, 198–201.
- (4) Manning, M. R.; Lowe, D. C.; Melhuish, W. H.; Sparks, R. J.; Wallace, G.; Brenninkmeijer, C. A. M.; McGill, R. C. The Use of Radiocarbon Measurements in Atmospheric Studies. *Radiocarbon* **1990**, *32*, 37–58.
- (5) Quay, P. D.; King, S. L.; Stutsman, J.; Wilbur, D. O.; Steele, L. P.; Fung, I.; Gammon, R. H.; Brown, T. A.; Farwell, G. W.; Grootes, P. M.; Schmidt, F. H. Carbon isotopic composition of atmospheric CH_4 : Fossil and biomass burning source strengths. *Global Biogeochem. Cycles* **1991**, *5*, 25–47.
- (6) Quay, P.; Stutsman, J.; Wilbur, D.; Snover, A.; Dlugokencky, E.; Brown, T. The isotopic composition of atmospheric methane. *Global Biogeochem. Cycles* **1999**, *13*, 445–461.
- (7) Lassey, K. R.; Lowe, D. C.; Smith, A. M. The atmospheric cycling of radiomethane and the "fossil fraction" of the methane source. *Atmos. Chem. Phys.* **2007**, *7*, 2141–2149.
- (8) Etiope, G.; Lassey, K. R.; Klusman, R. W.; Boschi, E. Reappraisal of the fossil methane budget and related emission from geologic sources. *Geophys. Res. Lett.* **2008**, *35*, 9.
- (9) Townsend-Small, A.; Tyler, S. C.; Pataki, D. E.; Xu, X.; Christensen, L. E. Isotopic measurements of atmospheric methane in Los Angeles, California, USA: Influence of "fugitive" fossil fuel emissions. *J. Geophys. Res.: Atmos.* **2012**, *117*, D7.

- (10) Graven, H.; Hocking, T.; Zazzeri, G. Detection of fossil and biogenic methane at regional scales using atmospheric radiocarbon. *Earth's Future* **2019**, *7*, 283–299.
- (11) Sparrow, K. J.; Kessler, J. D.; Southon, J. R.; Garcia-Tigueros, F.; Schreiner, K. M.; Ruppel, C. D.; Miller, J. B.; Lehman, S. J.; Xu, X. Limited contribution of ancient methane to surface waters of the U.S. Beaufort Sea shelf. *Sci. Adv.* **2018**, *4*, No. eaao4842.
- (12) Zazzeri, G.; Acuña Yeomans, E.; Graven, H. D. Global and regional emissions of radiocarbon from nuclear power plants from 1972 to 2016. *Radiocarbon* **2018**, *60*, 1067–1081.
- (13) Hmiel, B.; Petrenko, V. V.; Dyonisius, M. N.; Buizert, C.; Smith, A. M.; Place, P. F.; Harth, C.; Beaudette, R.; Hua, Q.; Yang, B.; Vimont, I.; Michel, S. E.; Severinghaus, J. P.; Etheridge, D.; Bromley, T.; Schmitt, J.; Fain, X.; Weiss, R. F.; Dlugokencky, E. Preindustrial $^{14}\text{CH}_4$ indicates greater anthropogenic fossil CH_4 emissions. *Nature* **2020**, *578*, 409–412.
- (14) Graven, H.; Allison, C. E.; Etheridge, D. M.; Hammer, S. ; Keeling, R. F.; Levin, I.; Meijer, H. A.; Rubino, M.; Tans, P. P.; Trudinger, C. M.; Vaughn, B. H. Compiled records of carbon isotopes in atmospheric CO_2 for historical simulations in CMIP6. *Geosci. Model Dev.* **2017**, *10*, 4405.
- (15) Eisma, R.; Vermeulen, A. T.; Van Der Borg, K. $^{14}\text{CH}_4$ Emissions from Nuclear Power Plants in Northwestern Europe. *Radiocarbon* **1995**, *37*, 475–483.
- (16) Espic, C.; Liechti, M.; Battaglia, M.; Paul, D.; Röckmann, T.; Szidat, S. Compound-specific radiocarbon analysis of atmospheric methane: a new pre-concentration and purification setup. *Radiocarbon* **2019**, *61*, 1461–1476.
- (17) Garnett, M. H.; Gulliver, P.; Billett, M. F. A rapid method to collect methane from peatland streams for radiocarbon analysis. *Ecology* **2016**, *9*, 113–121.
- (18) Palonen, V.; Usitalo, J.; Seppälä, E.; Oinonen, M. A portable methane sampling system for radiocarbon-based bioportion measurements and environmental CH_4 sourcing studies. *Rev. Sci. Instrum.* **2017**, *88*, 075102.
- (19) Sparrow, K. J.; Kessler, J. D. Efficient collection and preparation of methane from low concentration waters for natural abundance radiocarbon analysis. *Limnol. Oceanogr.: Methods* **2017**, *15*, 601–617.
- (20) Petrenko, V. V.; Smith, A. M.; Brailsford, G.; Riedel, K.; Hua, Q.; Lowe, D.; Severinghaus, J. P.; Levchenko, V.; Bromley, T.; Moss, R.; Mühle, J.; Brook, E. J. A New Method for Analyzing ^{14}C of Methane in Ancient Air Extracted from Glacial Ice. *Radiocarbon* **2008**, *50*, 53–73.
- (21) Garnett, M. H.; Newton, J. A.; Ascough, P. L. Advances in the radiocarbon analysis of carbon dioxide at the NERC radiocarbon facility (East Kilbride) using molecular sieve cartridges. *Radiocarbon* **2019**, *61*, 1855–1865.
- (22) Hardie, S. M. L.; Garnett, M. H.; Fallick, A. E.; Rowland, A. P.; Ostle, N. J. Carbon Dioxide Capture Using a Zeolite Molecular Sieve Sampling System for Isotopic Studies (^{13}C and ^{14}C) of Respiration. *Radiocarbon* **2005**, *47*, 441–451.
- (23) Schuur, E. A. G.; Trumbore, S. E. Partitioning sources of soil respiration in boreal black spruce forest using radiocarbon. *Global Change Biol.* **2006**, *12*, 165–176.
- (24) Taylor, A. J.; Lai, C.-T.; Hopkins, F. M.; Wharton, S.; Bible, K.; Xu, X.; Phillips, C.; Bush, S.; Ehleringer, J. R. Radiocarbon-based partitioning of soil respiration in an old-growth coniferous forest. *Ecosystems* **2015**, *18*, 459–470.
- (25) Walker, J. C.; Xu, X.; Fahrni, S. M.; Lupascu, M.; Czimeczik, C. I. Developing a passive trap for diffusive atmospheric $^{14}\text{CO}_2$ sampling. *Nucl. Instrum. Methods Phys. Res. Sect. B Beam Interact. Mater. Atoms* **2015**, *361*, 632–637.
- (26) Xu, X.; Trumbore, S. E.; Zheng, S.; Southon, J. R.; McDuffee, K. E.; Luttgen, M.; Liu, J. C. Modifying a sealed tube zinc reduction method for preparation of AMS graphite targets: reducing background and attaining high precision. *Nucl. Instrum. Methods Phys. Res. Sect. B Beam Interact. Mater. Atoms* **2007**, *259*, 320–329.
- (27) Wacker, L.; Fahrni, S. M.; Hajdas, I.; Molnar, M.; Synal, H.-A.; Szidat, S.; Zhang, Y. L. A versatile gas interface for routine radiocarbon analysis with a gas ion source. *Nucl. Instrum. Methods Phys. Res. Sect. B Beam Interact. Mater. Atoms* **2013**, *294*, 315–319.
- (28) Santos, G. M.; Southon, J. R.; Griffin, S.; Beaupre, S. R.; Druffel, E. R. M. Ultra small-mass AMS ^{14}C sample preparation and analyses at KCCAMS/UCI Facility. *Nucl. Instrum. Methods Phys. Res. Sect. B Beam Interact. Mater. Atoms* **2007**, *259*, 293–302.
- (29) Stuiver, M.; Polach, H. A. Discussion Reporting of ^{14}C Data. *Radiocarbon* **1977**, *19*, 355–363.
- (30) Stein, A. F.; Draxler, R. R.; Rolph, G. D.; Stunder, B. J. B.; Cohen, M. D.; Ngan, F. NOAA's HYSPLIT Atmospheric Transport and Dispersion Modeling System. *Bull. Am. Meteorol. Soc.* **2015**, *96*, 2059–2077.
- (31) Rolph, G.; Stein, A.; Stunder, B. Real-time environmental applications and display system: READY. *Environ. Model. Software* **2017**, *95*, 210–228.
- (32) Levin, I.; Bössinger, R.; Bonani, G.; Francey, R. J.; Kromer, B.; Münnich, K. O.; Suter, M.; Trivett, N. B. A.; Wöflli, W. Radiocarbon in atmospheric carbon dioxide and methane: global distribution and trends. *Radiocarbon after Four Decades*; Springer: New York, NY, 1992; pp 503–518.
- (33) Miller, J. B.; Lehman, S. J.; Verhulst, K. R.; Miller, C. E.; Duren, R. M.; Yadav, V.; Newman, S.; Sloop, C. D. Large and seasonally varying biospheric CO_2 fluxes in the Los Angeles megacity revealed by atmospheric radiocarbon. *Proc. Natl. Acad. Sci. U.S.A.* **2020**, *117*, 26681–26687.
- (34) Helfter, C.; Tremper, A. H.; Halios, C. H.; Kotthaus, S.; Björkegren, A.; Grimmond, C. S. B.; Barlow, J. F.; Nemitz, E. Spatial and temporal variability of urban fluxes of methane, carbon monoxide and carbon dioxide above London, UK. *Atmos. Chem. Phys.* **2016**, *16*, 10543–10557.
- (35) Zazzeri, G.; Lowry, D.; Fisher, R. E.; France, J. L.; Lanouisellé, M.; Grimmond, C. S. B.; Nisbet, E. G. Evaluating methane inventories by isotopic analysis in the London region. *Sci. Rep.* **2017**, *7*, 4854.