



Optimization of a network of compressors in parallel: Operational and maintenance planning – The air separation plant case



Georgios M. Kopanos^{a,b,*}, Dionysios P. Xenos^a, Matteo Ciccioiti^{c,d}, Efstratios N. Pistikopoulos^a, Nina F. Thornhill^a

^a Imperial College London, Department of Chemical Engineering, Centre for Process Systems Engineering, London SW7 2AZ, UK

^b Cranfield University, School of Energy, Environment & Agrifood, Bedfordshire MK43 0AL, UK

^c Imperial College London, Department of Mechanical Engineering, London SW7 2AZ, UK

^d BASF SE, Advanced Process Control, Automation Technology, 67056 Ludwigshafen, Germany

HIGHLIGHTS

- We study the detailed planning in networks of air compressors in air separation sites.
- Operational and several types of maintenance tasks for compressors are modeled.
- The power consumption in the compressors is expressed by regression functions.
- Our optimization framework can be directly used in a rolling horizon scheme.
- Our approach has been successfully applied to an industrial air separation plant.

ARTICLE INFO

Article history:

Received 18 July 2014

Received in revised form 20 January 2015

Accepted 21 January 2015

Available online 13 March 2015

Keywords:

Scheduling

Mixed integer programming

Rolling horizon

Compressors

Maintenance

Air separation

ABSTRACT

A general mathematical framework for the optimization of compressors operations in air separation plants that considers operating constraints for compressors, several types of maintenance policies and managerial aspects is presented. The proposed approach can be used in a rolling horizon scheme. The operating status, the power consumption, the startup and the shutdown costs for compressors, the compressor-to-header assignments as well as the outlet mass flow rates for compressed air and distillation products are optimized under full demand satisfaction. The power consumption in the compressors is expressed by regression functions that have been derived using technical and historical data. Several case studies of an industrial air separation plant are solved. The results demonstrate that the simultaneous optimization of maintenance and operational tasks of the compressors favor the generation of better solutions in terms of total costs.

© 2015 Elsevier Ltd. All rights reserved.

1. Introduction

In most process industries, compressed air, which is provided by compressors, is an indispensable utility for the main production processes. In industrial environments, several compressors are connected *in series* or *in parallel*, depending on the purpose of the system into which they are integrated. These networks of compressors can involve a number of compressor units that may differ in type of drive and technical specifications (e.g., maximum load capacity, efficiency and operational range).

Indeed, compressors are among the most energy-intensive parts of most industrial environments [1,2]. For this reason, they are good targets for energy and cost savings. As Xenos et al. [3] showed, the energy consumption of a network of compressors can be improved by sharing the load among them in order to take into advantage the different characteristics of the compressor units.

This work deals with the simultaneous optimization of the maintenance and the operational tasks of the compressors. The proposed methodology is applied to an industrial compressor station that is serving with compressed air a typical air separation plant and an energy-intensive large chemical plant. The prior literature on compressors optimization is limited. A brief literature review on the subject follows.

For the transfer of fluids, such as natural gas or ethylene, through long pipelines, several compressors or sub-networks of

* Corresponding author at: Cranfield University, School of Energy, Environment & Agrifood, Bedfordshire MK43 0AL, UK. Tel.: +44 123 475 8316; fax: +44 123 475 8230.

E-mail address: g.kopanos@cranfield.ac.uk (G.M. Kopanos).

Nomenclature

Indices/sets

$e \in E$	distillation products (e.g., N ₂ and O ₂)
$i \in I$	compressors
$j \in J$	headers
$n \in N$	process plants
$t \in T$	time periods
$u \in U$	distillation columns
$z \in Z$	storage tanks

Subsets

I^{dm}	set of compressors that are subject to fixed maintenance
I^{fm}	set of compressors that are subject to flexible maintenance
\tilde{I}_t^{dm}	set of compressors that are under maintenance at the beginning of the current scheduling horizon (maintenance task started in the previous scheduling horizon)
I_j	set of compressors that could serve header j
J_i	set of headers that are connected to compressor i
J_n	set of headers that are connected to process plant n
J_u	set of headers that are connected to distillation column u
U_z	set of distillation columns that are connected to storage tank z
Z_e	set of storage tanks that can store product e

Superscripts

es	earliest
ls	latest
max	maximum
min	minimum

Parameters

α_j	coefficient for the load curve of header j
β_j	coefficient for the load curve of header j
$\gamma^{(e,u)}$	outlet mass flow rate of product e from distillation column u
$\delta_{(1...3,i)}$	objective function coefficient factors for compressor i
ε_i	penalty cost for re-assigning header compressor i during its operation
$\zeta^{(e,t)}$	total demand for product e at the end of time period t
η_t	maximum number of simultaneous maintenance tasks in time period t
$\theta_{(n,t)}$	compressed air mass flow rate utility demand for process plant n during time period t
κ_t	conversion factor of mass flow to aggregated mass amount in time period t
λ_j	problem-specific large number that could represent the capacity of header j
μ_t	electricity price in time period t
v_i	duration of flexible maintenance task in compressor $i \in I^{fm}$
$\xi^{(e,z)}$	storage capacity for product e in storage tank $z \in Z_e$
ω_i	maximum on-line time after the startup of compressor i (maximum run time)
π_i	pressure ratio of compressor i
ρ_i	outlet compressed air mass flow rate from compressor i
σ_e	volumetric percentage of primary component of air e in the composition of air

τ_i	starting time for maintenance task in compressor i
$U_{(e,t)}$	cost for acquiring product e from external sources at the end of period t
ϕ_i	shutdown cost for compressor i
χ_i	startup cost for compressor i
ψ_i	minimum off-line time after the shutdown of compressor i (minimum shutdown time)
ω_i	minimum on-line time after the startup of compressor i (minimum run time)
$\tilde{\beta}_{(e,z)}$	initial inventory of product e in storage tank $z \in Z_e$
$\tilde{\eta}_{(i,t)}$	= 1, if compressor i is under pre-scheduled maintenance in time period t
\tilde{v}_i	total number of time periods that compressor i has been under maintenance (since the start of the maintenance task) at the end of the previous scheduling horizon
$\tilde{\varphi}_{(i,j)}$	active connection between compressor i and header j just before the beginning of the current scheduling horizon
$\tilde{\chi}_i$	operating status of compressor i just before the beginning of the current scheduling horizon
$\tilde{\psi}_i$	total number of time periods at the end of the past scheduling horizon that compressor i has been continuously off-line since its last shutdown
$\tilde{\omega}_i$	total number of time periods at the end of the past scheduling horizon that compressor i has been continuously on-line since its last startup

Continuous variables (non-negative)

$A_{(e,z,t)}$	amount of product e extracted from storage tank $z \in Z_e$ at the end of time period t
$B_{(e,z,t)}$	inventory level of product e in storage tank $z \in Z_e$ at the end of time period t
$C_{(e,u,t)}$	mass flow rate of product e from distillation column u in time period t
$L_{(e,u,z,t)}$	mass amount of product e from distillation column u that is sent to storage tank $z \in Z_e$ in time period t
$M_{(i,j,t)}$	compressed air mass flow rate from compressor i supplied to header $j \in J_i$ in time period t
$\bar{M}_{(i,j,t)}$	total compressed air mass flow rate supplied to header $j \in J_i$ that is served by compressor i in time period t (auxiliary variable)
$O_{(e,t)}$	amount of product e acquired from external sources at the end of time period t
$P_{(i,j,t)}$	outlet pressure of compressor i that serves header $j \in J_i$ in time period t

Binary variables

$D_{(i,t)}$	= 1, if compressor i changes header from time period $t - 1$ to t
$F_{(i,t)}$	= 1, if compressor i shuts down at the beginning of time period t
$S_{(i,t)}$	= 1, if compressor i starts up at the beginning of time period t
$X_{(i,t)}$	= 1, if compressor i is operating during time period t
$Y_{(i,j,t)}$	= 1, if compressor i serves header $j \in J_i$ during time period t
$W_{(i,t)}$	= 1, if a flexible maintenance task starts in compressor i at the beginning of time period t

compressors are placed in series along the pipeline so as to provide the necessary pressure ratio and overcome the pressure drop due to friction losses. The optimization of natural gas pipelines received considerable attention in the last five decades [4–6]. Most of the works on natural gas networks emphasize the use of optimal control, usually by employing dynamic programming. However, the operational aspects such as startup and shutdown, timing constraints and maintenance of the compressors are typically neither modeled explicitly nor optimized. The contributions from Uraikul et al. [7] and Nguyen and Chan [8] are some representative works that include some operational decisions for the compressors. However, both studies assumed that compressors operate at a single operating point (i.e., non-partial load operation), and therefore the mass flow of individual compressors was not considered in the optimization.

Networks of parallel compressors are typically used to distribute a fluid material from an upstream process to other downstream processes. Few researchers have addressed the optimization of such networks of compressors. For example, van den Heever and Grossmann [9] proposed a mathematical programming approach for the production planning and reactive scheduling problem of a hydrogen supply network. Emphasis was placed on the modeling of the pipeline network and not on the operation of the compressors. In particular, minimum run and shutdown times and costs for compressors were ignored. Camponogara et al. [10] presented a real-time optimization framework for gas-lift compressors in oil fields, neglecting startup and shutdown decisions. Han et al. [11] studied the optimization of the air- and gas-supply network of a chemical plant. The optimization of compressors startup and shutdown actions was not considered. The previous works studied the optimization of network of compressors without emphasizing on their operational aspects, such as startups and shutdowns. Therefore, there is space for research on the subject.

There are several contributions in the literature describing process applications with features similar to those found in the optimal operation of compressors. Among them, Rong and Lahdelma [12] presented a linear programming planning model and optimization algorithm for trigeneration. Thorin et al. [13] proposed a mathematical programming model for the long-term planning of cogeneration systems in a competitive market environment. Kopanos et al. [14] presented an optimization framework for the energy production planning of a network of combined heat and power generators. Zhuan and Xia [15] proposed a dynamic programming algorithm for the operations scheduling of a pumping station with multiple pumps. Recently, Kopanos and Pistikopoulos [16] introduced a reactive scheduling rolling horizon framework based on a state-space representation and multiparametric programming. The proposed approach was applied in a network of combined heat and power units.

These articles offer a starting point for the work presented here. However, these papers do not address the simultaneous optimization of maintenance and operational tasks of the compressors, showing that there are open questions. To the best of our knowledge, there is no previous research in the open literature that considers the simultaneous optimization of operational and maintenance activities in network of compressors. This topic is addressed in the current paper.

The paper is laid out as follows. Section 2 provides a brief description of multistage centrifugal compressor systems and the modeling of their power consumption. Next, in Section 3, the air separation process is briefly described and some related works on the subject of this paper are mentioned. The problem statement is formally defined in Section 4, and a general mathematical framework for the problem of interest is presented in Section 5. Then, some extensions to the basic framework are provided in Section 6. In Section 7, a number of problem instances, including industrial case studies from

a major air separation plant of BASF in Germany, are solved by the proposed approach, and the results are presented and further discussed. Finally, some concluding remarks along with ongoing research directions are provided in Section 8.

2. Description and modeling of multistage centrifugal compressors

This section describes a multistage centrifugal compressor system, which is considered in this paper, and provides the methodology used to derive the power consumption of the motors of the compressors as a function of key process parameters. The load curves of the headers are estimated from industrial process data.

2.1. Description of a multistage centrifugal compressor system

The current work considers a case study of an air separation plant that involves a number of air multistage centrifugal compressors with dissimilar characteristics in terms of performance and power rate. In a multistage centrifugal compressor, several single stages of centrifugal compressors are arranged in series by being attached to a rotating shaft. This structure is employed to increase the total discharge pressure compared to this a single-stage compressor could achieve.

Fig. 1a shows an illustrative example of an operating point of a compressor connected with a downstream process at fixed ambient conditions. The figure shows the characteristic of a compressor which intersects with the characteristic of a downstream process, which is called a load curve. The intersection between the two curves gives the conditions of the current operation and provides information regarding the mass flow that the compressor provides (can be estimated in the horizontal axis) to the downstream process and the discharge pressure (can be estimated in the vertical axis). The load curve of the downstream process can change due to disturbances, hence the conditions of the operation change. The methods to control a compressor at desired operational conditions have been described in Xenos et al. [3].

2.2. Modeling of the power consumption

The modeling of the power consumption of the motor of a multistage compressor can be derived from process data. Xenos et al. [17] presented a black box method to represent the power consumption of the motor (PM^{el}) as a function of: (i) process variables such as mass flows (M) and outlet pressures (P), and (ii) parameters such as the mass flow of the cooling water (M^{water}) and the inlet pressure (P^{in}). Thereby, the output power of the motor can be calculated by an expression of this type:

$$PM_{(i,j,t)}^{el} = f(P_{(i,j,t)}, M_{(i,j,t)}, M_{(i,t)}^{water}, P_t^{in}, \delta_{(1,i)}, \delta_{(2,i)}, \delta_{(3,i)})$$

This expression can describe compressors with Inlet Guide Vanes (IGVs) or inlet throttling control schemes. In the first case, the operating point of the compressor changes through the manipulation of the angle of the inlet guide vane that controls the mass flow rate. In the latter case, the operating point of the compressor changes by increasing the losses at the inlet of the compressor and in that way the inlet pressure can be modified. The industrial case does not provide the inlet pressure at the eye of the compressor, however the measurement of the inlet pressure provided from the industrial partner is at the filter of the inlet duct of the compressors which is approximately 1 bar for all compressors. This work does not focus on the estimation of the manipulated variables, i.e., angles of IGVs and throttling valves. Therefore, the expression presented above describes well both cases of compressors for the purpose of scheduling, since the variable that is taken

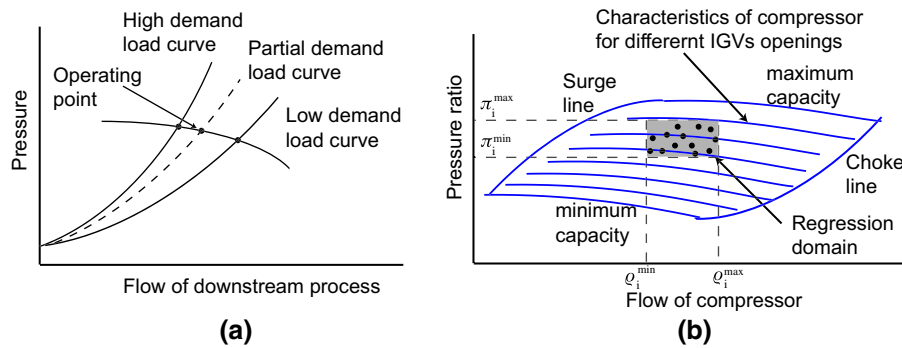

Fig. 1. (a) Operating point of compressors in parallel and (b) regression domain and feasible window of operation of a compressor with IGVs.

into account in the optimization is the outlet pressure P . The δ coefficients of this expression are calculated using data fitting methods in Matlab™ [17].

The efficiencies of the compressors and motors are embedded in the power consumption expression. The reason to use this method is that the efficiencies cannot be explicitly modeled in this case study because many measurements are not available. The measurements are essential to carry out thermodynamic calculations to estimate the efficiency of the compressor. Finally, Xenos et al. [3] demonstrated that two similar compressors consume different amounts of energy at the same operating conditions.

It is important to notice that the feasible window of operation of the compressor used for the optimization is not defined from the actual physical limits of the compressor, i.e., surge, choke, and minimum and maximum power. The feasible window of operation of the compressor is defined from the domain of the regression model [18]. The group of all the operating points of a collected data set derives the regression domain of the model as can be seen in Fig. 1b. It is also known from the plant that the operators operated well within the physical limits (surge and choke) of the compressors during the past operation. The physical limits of the compressor namely surge, choke and driver limits, as well as minimum and maximum speeds (i.e. corresponding to minimum and maximum power) are presented in Xenos et al. [3]. The approach of Xenos et al. [3] is required because operators may not have operated the compressors over their full operational range in the collected data set. Therefore, a partial compressor map is captured in the regression models. This leads to a solution in a confined space. Nevertheless, the operation coming from the optimization using this operational space is expected more efficient than operation without optimization. Finally, the extrapolation of the models leads to inaccurate results as it has been observed in a numerical study during the development of the regression models.

2.3. Load curves of the headers (feasible region)

The load curve of the downstream process, header and distillation column, represents the pressure drop of the header and the operational pressure at the inlet of the column. A linear relationship between mass flow, which is equal to the summation of the individual mass flows of the compressors operating to that header, provided in the header and outlet pressure of the compressor can represent the load curve by applying regression to available historical data.

3. The air separation process

The air separation process separates atmospheric air into its primary components which are mainly nitrogen, oxygen, and argon. Other rare inert gases (e.g., neon and helium) in a much smaller

volumetric percentage are also present. The most common air separation method for large-scale production is by means of cryogenic distillation, although other technologies such as membrane separation also exist [19]. Since this work focuses on cryogenic air separation, a brief description of a typical cryogenic air separation process follows.

3.1. Cryogenic air separation process

The cryogenic air separation starts with the intake of atmospheric air that is usually filtered to remove dust. This air is compressed and re-cooled with the use of an after-cooler. Then, the compressed air is purified through molecular sieves so as to remove carbon dioxide, gaseous hydrocarbons and water vapor. The compressed air is cooled to cryogenic temperatures in the main heat exchanger. According to Zhu et al. [20], the compressed air is divided into two streams, the main stream and a low pressure stream (after the expansion of the main stream). These streams enter a distillation column which separates the air to its primary components. Fig. 2 presents a simplified structure of a cryogenic air separation process having as products oxygen and nitrogen. Gaseous nitrogen collects at the top of the distillation column, and liquid oxygen collects at the bottom of the distillation column. The oxygen at the bottom is vaporized while nitrogen in liquid form is introduced at the top of the column, and this process continues as long as is required to reach a desired level of purity.

The products of the distillation can be transferred via pipelines to inter-connected local industrial customers. For pipeline transfer, products should be vaporized into their gaseous form. For other longer-distance customers, it is more practical and economical to transfer them in a liquid form. In this case, the products of the distillation pass through a liquefier and then they are placed into product-dedicated storage tanks before their shipment by marine or land transportation modes.

The cryogenic separation of air is an energy-intensive process that requires significant heat integration of heat exchangers and distillation columns, in order to improve the energy efficiency of the overall process. Indeed, most of the previous research works have been dedicated to the heat integration of air separation plants. In cryogenic air separation, the network of compressors and the liquefiers are the main sources of power consumption. Fig. 3 displays a representative layout of a cryogenic air separation plant.

3.2. Operational planning in air separation plants

There is a limited number of works concerning with the operational management of air separation systems. Ierapetritou et al. [21] presented a linear Mixed Integer Programming (MIP) formulation for the operational planning in an air separation plant under the objective to minimize the total operating cost. The operation

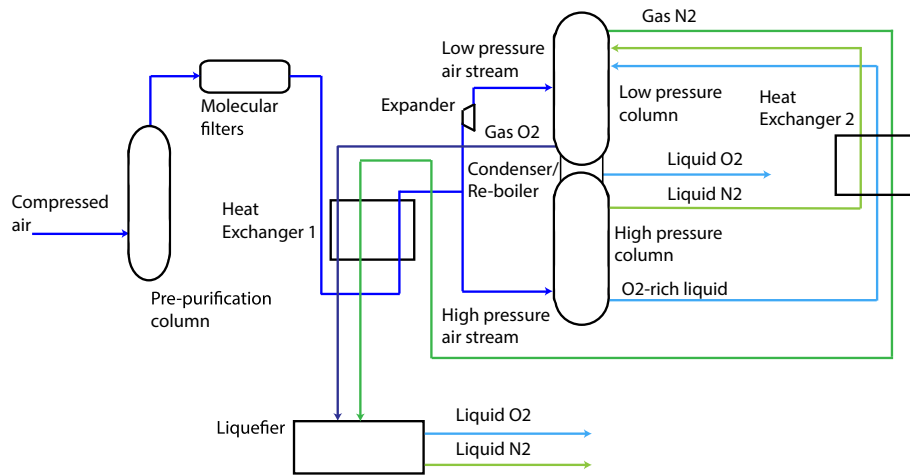

Fig. 2. Simplified structure of a cryogenic air separation process.

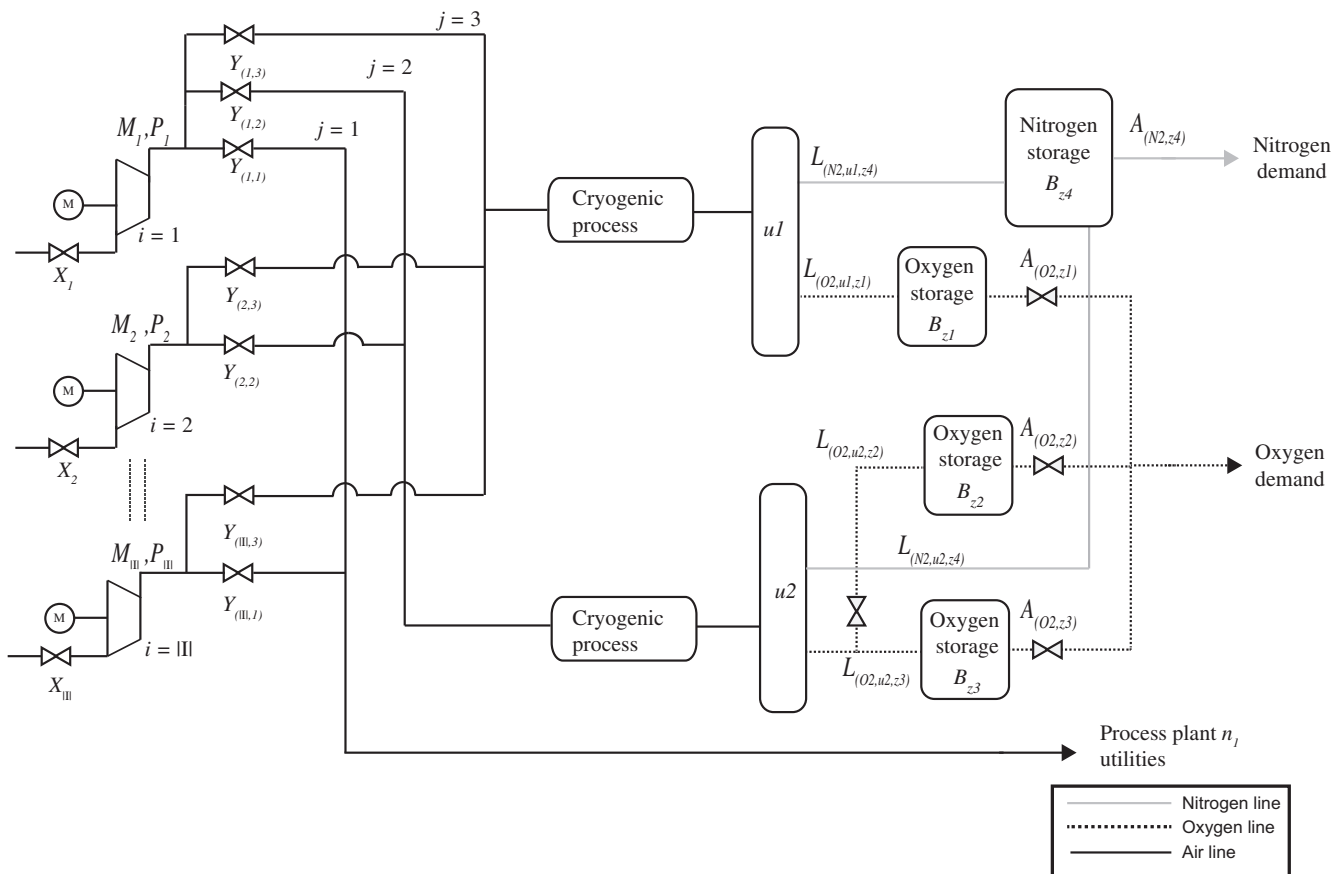

Fig. 3. Representative layout of a cryogenic air separation plant.

of the plant was described by three different plant operation modes (regular, assisted, shutdown) that vary with respect to operational efficiency and energy requirements. An operating mode defines a convex set that characterizes the feasible operating space of a configuration. Binary variables were used to represent operating modes and switches among the different modes of operation. The model of Ierapetritou et al. [21] can generate the schedule of process operation modes and production rates. Along the same lines, Karwan and Kebli [22] proposed a MIP model that additionally considers product losses during configuration changes, while Mitra et al. [23] presented a MIP formulation that captures the transient

behavior between different operating modes. Following a different approach, Zhu et al. [20] presented a non-linear programming formulation that has as constraints a process model for the air separation process that accounts for mass and energy balances for the distillation columns, heat exchangers, and throttle valves. The above articles focused on the planning of the operational modes of the overall air separation plant, but they did not address the detailed scheduling of the main components of the air separation plant that are the compressors and the distillation columns.

This paper addresses an operational issue that has not been considered by previous authors. Its distinctive feature is the

detailed modeling and optimization of operations of the network of compressors of the air separation plant, since compressors are the major power consumers. The operating status of compressors (e.g., on, operating, off) and their assignment to headers are optimized. Additionally, the optimization model takes into account the costs of compressor startup and shutdown, and operating constraints such as minimum run time and duration of a shutdown. Outlet compressed air mass flow rates (from any compressor) and outlet product mass flow rates from distillation columns to product-dedicated storage tanks are optimized so as to fully satisfy the demand for products. The power consumption in the compressors is expressed by regression functions that have been derived from technical and historical data. Finally, several maintenance activities for compressors and compressor-to-header changes are also considered as extensions of the proposed optimization framework. A formal definition of the problem addressed in this paper follows in the next section.

4. Problem statement

This work deals with the operations optimization problem in networks that consist of a finite number of compressors, distillation columns, headers, and storage tanks. In this study, we mainly focus on the optimization of the operations of the network of compressors, which is the major energy-consuming part of the air separation plant. The resulting problem is formally defined in terms of the following items:

- A given scheduling horizon that is divided into a set of equal-length time periods $t \in T$, as shown in Fig. 4.
- A set of different compressors $i \in I$ that have a maximum (minimum) outlet compressed air mass flow rate ρ_i^{\max} (ρ_i^{\min}) and pressure ratio π_i^{\max} (π_i^{\min}). The minimum on-line time after the startup of compressor i (minimum run time) ω_i and the minimum off-line time after the shutdown of compressor i (minimum shutdown time) ψ_i , as well as the associated costs for startup (χ_i) and shutdown (ϕ_i) are also given.
- A set of distillation columns $u \in U$ that separate air into its primary components $e \in E$. Maximum (minimum) outlet mass flow rates for the products of the distillation columns $\gamma_{(e,u)}^{\max}$ ($\gamma_{(e,u)}^{\min}$) are given.
- A number of local process plants $n \in N$ that are characterized by a given demand for compressed air $\theta_{(n,t)}$ per time period t .
- A set of headers $j \in J$ that receive compressed air from the compressors (J_i). The headers supply with compressed air the distillation columns (J_u) of the air separation network and the local process plants (J_n).
- A set of storage tanks $z \in Z$ which are connected with the outlets of the distillation columns (U_z), and can store specific products (Z_e). Every storage tank has a given maximum (minimum) storage capacity $\xi_{(e,z)}^{\max}$ ($\xi_{(e,z)}^{\min}$).
- A given demand for the products of the distillation $\zeta_{(e,t)}$ at the end of each time period t .
- Products e can be also acquired from external sources in a given cost $v_{(e,t)}$, if the air separation plant cannot fully meet the demand for products.
- A given electricity price μ_t for time period t . The electricity tariff can be fixed, or time-varying (e.g., following time-of-use rates, or real-time prices).

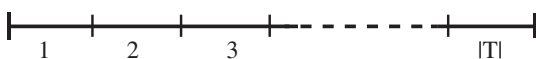

Fig. 4. Discretization of the scheduling time horizon.

All parameters are assumed to be deterministic. The discharge pressures of all compressors feeding the same header are assumed the same, which is reasonable because the connected pipes between the exits of the compressors and the main header are short. Each header is connected to a single distillation column or a local process plant (i.e., one destination point). The products of distillation columns are stored in product-dedicated storage tanks through which the demand for these products is satisfied. Each one of the storage tanks could be connected to multiple distillation columns. Also, a compressor can serve at most one header at a time, and during its operation can change header. Generally speaking, the existence of storage tanks allows decoupling the operation of the plant from the demand for products, and gives the required flexibility for the operational planning of the air separation plant.

For every time period t , the key decisions to be made by the administrator of the network of compressors and the overall air separation plant are:

- the operating status (e.g., startup, in operation, shutdown) of every compressor i ;
- the assignment of the operating compressors to headers;
- the compressed air mass flow rate from the operating compressors to each header;
- the total amount of products provided from each distillation column to which storage tanks; and
- the amount of air separation products acquired from external sources.

The aim is to minimize the total cost, which encompasses startup, shutdown and operating costs of compressors as well as costs for acquiring products from external sources. The demand for the air separation products and the compressed air for utilities should be fully satisfied.

5. Mathematical framework

In this section, a linear mixed integer programming framework is presented for the modeling and optimization of operations of compressor networks as those described in Section 4. To facilitate the presentation of the proposed model, uppercase Latin letters for optimization variables and sets, and lowercase Greek letters for parameters have been used.

5.1. Minimum run and shutdown time for compressors

Minimum run and shutdown times are modeled by defining the following three sets of binary decision variables:

$$X_{(i,t)} = \begin{cases} 1, & \text{if compressor } i \text{ is in operation during time period } t \\ 0, & \text{otherwise} \end{cases}$$

$$S_{(i,t)} = \begin{cases} 1, & \text{if compressor } i \text{ starts up at the beginning of time period } t \\ 0, & \text{otherwise} \end{cases}$$

$$F_{(i,t)} = \begin{cases} 1, & \text{if compressor } i \text{ shuts down at the beginning of time period } t \\ 0, & \text{otherwise} \end{cases}$$

Constraints (1) and (2) define $S_{(i,t)}$ and $F_{(i,t)}$ binary variables through variables $X_{(i,t)}$. Parameters $\tilde{\chi}_i$ denote the operating status (i.e., on or off) of compressor i just before the beginning of the current scheduling horizon and can be calculated through parameters $\hat{\varphi}_{(i,j)}$, which represent the active connection of compressor i to header j before the beginning of the current scheduling horizon. It is obvious that $\tilde{\chi}_i = \sum_{j \in J_i} \hat{\varphi}_{(i,j)}$ since a compressor can connect to at most one header at a time.

$$S_{(i,t)} - F_{(i,t)} = X_{(i,t)} - \tilde{\gamma}_i \quad \forall i \in I, t \in T : t = 1 \quad (1)$$

$$S_{(i,t)} - F_{(i,t)} = X_{(i,t)} - X_{(i,t-1)} \quad \forall i \in I, t \in T : t > 1$$

$$S_{(i,t)} + F_{(i,t)} \leq 1 \quad \forall i \in I, t \in T \quad (2)$$

Constraints (2) could be omitted, if startup and shutdown costs are part of the objective function. For every compressor, constraints (3) and (4) model the minimum run and shutdown time, respectively.

$$X_{(i,t)} \geq \sum_{t'=\max\{1,t-\omega_i+1\}}^t S_{(i,t')} \quad \forall i \in I, t \in T : \omega_i > 1 \quad (3)$$

$$1 - X_{(i,t)} \geq \sum_{t'=\max\{1,t-\psi_i+1\}}^t F_{(i,t')} \quad \forall i \in I, t \in T : \psi_i > 1 \quad (4)$$

5.2. Assignment of compressors to headers

An additional binary decision variable is introduced to denote the allocation of available compressors to headers:

$$Y_{(i,j,t)} = \begin{cases} 1, & \text{if compressor } i \text{ serves header } j \in J_i \text{ in time period } t \\ 0, & \text{otherwise} \end{cases}$$

A compressor i can supply compressed air to at most one header $j \in J_i$ at a time, according to:

$$\sum_{j \in J_i} Y_{(i,j,t)} = X_{(i,t)} \quad \forall i \in I, t \in T \quad (5)$$

5.3. Feasible windows of operation for compressors

For any compressor i , constraints (6) and (7) denote the lower and upper bounds on the outlet compressed air mass flow rate and outlet pressure that the compressor could operate:

$$\rho_i^{\min} Y_{(i,j,t)} \leq M_{(i,j,t)} \leq \rho_i^{\max} Y_{(i,j,t)} \quad \forall i \in I, j \in J_i, t \in T \quad (6)$$

$$\pi_i^{\min} Y_{(i,j,t)} \leq P_{(i,j,t)} \leq \pi_i^{\max} Y_{(i,j,t)} \quad \forall i \in I, j \in J_i, t \in T \quad (7)$$

From constraints (7), if $Y_{(i,j,t)} = 0$ then $P_{(i,j,t)} = 0$. This zero pressure has no physical meaning, and actually it is just used for the calculation of the power consumption cost term in the objective function.

5.4. Outlet pressure for compressors

The outlet pressure of any compressor is equal to the pressure of the header that the compressor serves, and is given by the corresponding load curve:

$$P_{(i,j,t)} = \alpha_j \bar{M}_{(i,j,t)} + \beta_j Y_{(i,j,t)} \quad \forall i \in I, j \in J_i, t \in T \quad (8)$$

Parameters α_j and β_j represent the coefficients for the load curve of header j . In order to avoid non-linearities in the load curve constraints (8), we have introduced auxiliary variables $\bar{M}_{(i,j,t)}$ that denote the total compressed air mass flow rate in the header j which is served by compressor i during time period t . Non-negative variables $\bar{M}_{(i,j,t)}$ are modeled through the following set of big-M constraints:

$$\bar{M}_{(i,j,t)} \geq \sum_{i' \in J_j} M_{(i',j,t)} - \lambda_j (1 - Y_{(i,j,t)}) \quad \forall i \in I, j \in J_i, t \in T$$

$$\bar{M}_{(i,j,t)} \leq \sum_{i' \in J_j} M_{(i',j,t)} + \lambda_j (1 - Y_{(i,j,t)}) \quad \forall i \in I, j \in J_i, t \in T \quad (9)$$

$$\bar{M}_{(i,j,t)} \leq \lambda_j Y_{(i,j,t)} \quad \forall i \in I, j \in J_i, t \in T$$

Parameters λ_j are problem-specific large numbers that can be usually calculated by considering the maximum capacity of header j .

5.5. Demand for compressed air utility

The network of compressors should satisfy the compressed air utility demand $\theta_{(n,t)}$ for every process plant n in each time period t , according to:

$$\sum_{i \in I} \sum_{j \in (J_n \cap J_i)} M_{(i,j,t)} \geq \theta_{(n,t)} \quad \forall n \in N, t \in T \quad (10)$$

5.6. Distillation columns operations: mass flow rates for products

The outlet mass flow rate of product e from each distillation column u during each time period t is given by:

$$C_{(e,u,t)} = \sigma_e \sum_{i \in I} \sum_{j \in (J_u \cap J_i)} M_{(i,j,t)} \quad \forall u \in U, t \in T \quad (11)$$

Constraints (12) provide lower and upper bounds on the outlet mass flow rate of product e from each distillation column.

$$\gamma_{(e,u)}^{\min} \leq C_{(e,u,t)} \leq \gamma_{(e,u)}^{\max} \quad \forall e \in E, u \in U, t \in T \quad (12)$$

5.7. Storage tanks mass balances

The total amount of products e from the distillation columns u that is disposed to each storage tank $z \in Z_e$ during time period t is represented by variables $L_{(e,u,z,t)}$, and is given by:

$$\sum_{z \in Z_e} L_{(e,u,z,t)} = \kappa_t C_{(e,u,t)} \quad \forall e \in E, u \in U, t \in T \quad (13)$$

Hence, the demand for any product e in each time period t is met by extracting the necessary amount of product ($A_{(e,z,t)}$) from the storage tanks $z \in Z_e$. The products could be also acquired from external sources ($O_{(e,t)}$), if the demand cannot be fully met by the internal production network.

$$\sum_{z \in Z_e} A_{(e,z,t)} + O_{(e,t)} = \zeta_{(e,t)} \quad \forall e \in E, t \in T \quad (14)$$

Constraints (15) correspond to the mass balance in the product storage tanks under the complete satisfaction of the demand for products. Variables $B_{(e,z,t)}$ denote the amount of product e that is stored in storage tank $z \in Z_e$ at the end of time period t . Parameter $\tilde{\beta}_{(e,z)}$ represents the initial inventory of product e in storage tank $z \in Z_e$.

$$B_{(e,z,t)} = \tilde{\beta}_{(e,z)} + \sum_{u \in U_z} L_{(e,u,z,t)} - A_{(e,z,t)} \quad \forall e \in E, z \in Z_e, t \in T : t = 1$$

$$B_{(e,z,t)} = B_{(e,z,t-1)} + \sum_{u \in U_z} L_{(e,u,z,t)} - A_{(e,z,t)} \quad \forall e \in E, z \in Z_e, t \in T : t > 1 \quad (15)$$

Constraints (16) define the lower and the upper inventory bounds. The upper inventory bound represents the storage capacity of the storage tank. Safety stocks could be represented by the lower inventory bound.

$$\zeta_{(e,z)}^{\min} \leq B_{(e,z,t)} \leq \zeta_{(e,z)}^{\max} \quad \forall e \in E, z \in Z_e, t \in T \quad (16)$$

The proposed mathematical framework can be also used to cope with scheduling and planning problems in multiple (i.e., multi-site) networks of compressors. The presented model can be directly applied in the multi-site case, if no interchange of products is allowed between the storage tanks of the different sites. Otherwise, the mass balance equations should be accordingly modified.

5.8. Initial state of the network

At this point, it should be emphasized that the initial inventory level of every storage tank $\tilde{\beta}_{(e,z)}$ (constraints (15)) and the initial

operating status of every compressor $\tilde{\varphi}_{(i,j)}$ ($\rightarrow \tilde{\chi}_i$) (constraints (1)) partially describe the initial state of the network. It is also necessary to provide information on the startup and shutdown from the previous scheduling horizon. The following set of constraints allows past information regarding startup and shutdown to be carried over at the beginning of the current scheduling horizon:

$$X_{(i,t)} = 1 \quad \forall i \in I, t = 1, \dots, (\omega_i - \tilde{\omega}_i) : 0 < \tilde{\omega}_i < \omega_i \quad (17)$$

$$X_{(i,t)} = 0 \quad \forall i \in I, t = 1, \dots, (\psi_i - \tilde{\psi}_i) : 0 < \tilde{\psi}_i < \psi_i \quad (18)$$

Parameters $\tilde{\omega}_i$ ($\tilde{\psi}_i$) denote the total number of time periods at the end of the past scheduling horizon that compressor i has been operating (not operating) since its last startup (shutdown). Fig. 5 shows an illustrative example of how the past startup information is captured from the above constraints.

5.9. Objective function

The optimization goal in this study is to minimize the total startup, shutdown and power consumption costs of the compressors as well as the procurement cost of products from external sources. As already mentioned in Section 2.2, power consumption is a function of the outlet mass flow rate, the outlet pressure, the consumption of cooling water, and the ambient conditions. This function is usually represented well by a quadratic form, however a more simple linear form could be derived in some cases. The advantage of a linear objective function is the significant reduced computational effort to reach optimality, however a higher error in the results is usually expected. The linear total cost objective function considered here is given by:

$$\begin{aligned} \min \sum_{t \in T} \sum_{e \in E} (v_{(e,t)} O_{(e,t)}) + \sum_{t \in T} \sum_{i \in I} (\chi_i S_{(i,t)} + \phi_i F_{(i,t)}) \\ + \sum_{t \in T} \mu_t \sum_{i \in I} \sum_{j \in J_i} (\delta_{(1,i)} Y_{(i,j,t)} + \delta_{(2,i)} M_{(i,j,t)} + \delta_{(3,i)} P_{(i,j,t)}) \end{aligned} \quad (19)$$

Parameters $\delta_{(1..3,i)}$ correspond to power consumption normalized coefficient factors for every compressor i , and mainly depend on information related to cooling water consumption and ambient conditions.

6. Extensions on the basic mathematical framework

In this part, we discuss and provide some extensions of practical interest on the general mathematical framework presented above.

6.1. Optimizing the compressor-to-header assignment changes

Any compressor i during its operation can change headers from one time period to another. So far, no cost has been considered for these changes of header. Due to this fact, solutions that are characterized by many (and sometimes unnecessary) header changes may be obtained. In practice, compressor-to-header re-assignments are typically done manually through valve opening or closing by the technical personnel of the industry. For this reason, a small number of header changes is more desirable so as to: (i) reduce the utilization of personnel; (ii) decrease the probability for potential human errors; (iii) favor a more smooth operation (i.e., easier to implement, control, and revise) of the overall network of compressors; and (iv) avoid energy losses during the header change due to venting of the compressed air to the atmosphere. Therefore, in this study the total number of these compressor-to-header changes is optimized, and we propose the incorporation of an associated penalty cost term (ϵ_i) in the initial objective function.

In order to model compressor-to-header changes, the following set of binary decisions variables has been introduced:

$$D_{(i,t)} = \begin{cases} 1, & \text{if compressor } i \text{ changes header from time period } t-1 \text{ to } t \\ 0, & \text{otherwise} \end{cases}$$

In that way, the compressor-to-header changes could be modeled by:

$$\begin{aligned} D_{(i,t)} \geq Y_{(i,j,t)} - \tilde{\varphi}_{(i,j)} - S_{(i,t)} \quad \forall i \in I, j \in J_i, t \in T : t = 1 \\ D_{(i,t)} \geq Y_{(i,j,t)} - Y_{(i,j,t-1)} - S_{(i,t)} \quad \forall i \in I, j \in J_i, t \in T : t > 1 \end{aligned} \quad (20)$$

Fig. 6 depicts an illustrative example of how constraints (20) work. Observe that due to the introduction of a penalty cost for header changes, binary variables $D_{(i,t)}$ tend to zero.

The modified optimization goal that contains the compressor-to-header changes penalty cost term is given by:

$$\begin{aligned} \sum_{t \in T} \sum_{i \in I} (\epsilon_i D_{(i,t)}) + \sum_{t \in T} \sum_{e \in E} (v_{(e,t)} O_{(e,t)}) + \sum_{t \in T} \sum_{i \in I} (\chi_i S_{(i,t)} + \phi_i F_{(i,t)}) \\ + \sum_{t \in T} \mu_t \sum_{i \in I} \sum_{j \in J_i} (\delta_{(1,i)} Y_{(i,j,t)} + \delta_{(2,i)} M_{(i,j,t)} + \delta_{(3,i)} P_{(i,j,t)}) \end{aligned} \quad (19')$$

6.2. Preventive maintenance of compressors

In most relevant industrial environments, the maintenance tasks of compressors are typically predefined before the operations

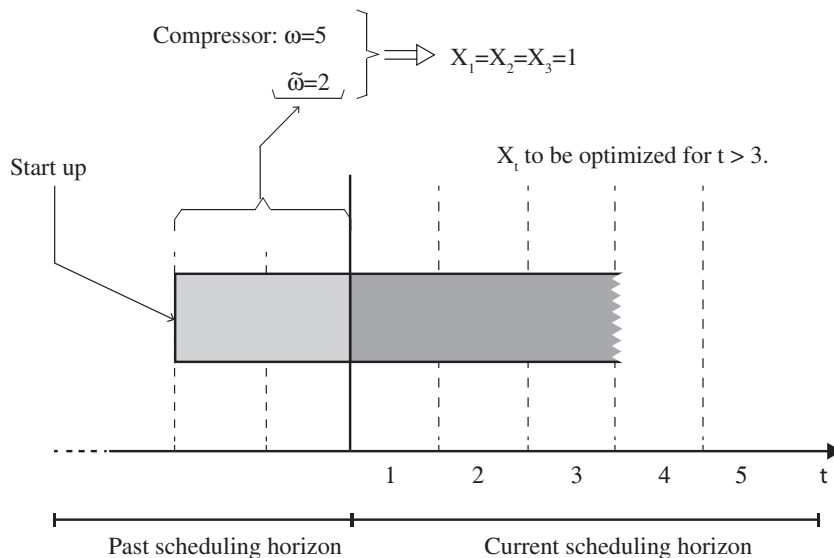

Fig. 5. Carryover of past startup information to model minimum run.

optimization of the production system. The duration v_i of a maintenance task is generally known. Here, we consider three types of preventive maintenance tasks: (i) *runtime-based*, (ii) *fixed*, and (iii) *flexible*. The first type of maintenance is related to the maximum run time of the compressors. Fixed maintenance tasks take place in a predefined time horizon, such that the starting (completion) times of the maintenance tasks are known. Generally speaking, flexible maintenance tasks should take place within a predefined time window, and their exact starting (completion) times are additional decisions to be made.

Runtime-based maintenance tasks. The performance of a compressor depends on its current condition. Since the performance of the compressor deteriorates during its utilization, there is often a time limit on its continuous operation. After this so-called maximum run time (o_i), the compressor should be switched off, and maintenance takes place to prevent mechanical damage and the energy-inefficient use of the compressor. The runtime-based maintenance policy can be considered as a simplified case of the condition-based maintenance policy [24]. For the sake of simplicity here, the duration of these types of maintenance tasks are considered to be equal to the minimum shutdown time. For every compressor, the maximum run time constraints are given by:

$$\sum_{t'=\max\{1,t-o_i\}}^t X_{(i,t')} \leq o_i \quad \forall i \in I, t \in T \quad (21)$$

Notice that if compressor i has been in operation at the end of the previous scheduling horizon (i.e., $\tilde{\omega}_i > 1$), then the total run time from its last startup of the past horizon should be carried over to the current scheduling horizon so as to model successfully the maximum run time limits. Constraints (22) describe the initial state of the network in respect of the maximum run time.

$$\sum_{t'=\max\{1,t-(o_i-\tilde{\omega}_i)\}}^t X_{(i,t')} \leq (o_i - \tilde{\omega}_i) \quad \forall i \in I, t = (o_i - \tilde{\omega}_i + 1) : \tilde{\omega}_i > 1 \quad (22)$$

Finally, if there is a maximum time that compressors could remain idle (i.e., maximum idle time), similar types of constraints could be easily derived.

Fixed maintenance tasks. The starting times τ_i of this type of maintenance tasks are known. For this reason, fixed maintenance

tasks can be readily modeled by setting to zero (from the starting to the completion of the maintenance task) the operating binary variables $X_{(i,t)}$ of compressors $i \in I^{dm} \subseteq I$ that are subject to fixed maintenance:

$$X_{(i,t)} = 0 \quad \forall i \in I^{dm}, t = \tau_i, \dots, (\tau_i + v_i - 1) \quad (23)$$

These constraints generally hold, since the maintenance duration is typically at least equal to the minimum shutdown time.

Due to the presence of maintenance tasks, the initial maintenance state (i.e., under maintenance or not) of every compressor should be carried over from the previous scheduling horizon. To consider this properly, for the compressors $i \in \tilde{I}^{dm}$ that are under maintenance at the beginning of the current scheduling horizon and their maintenance tasks had already started in the previous scheduling horizon, constraints (23) are modified:

$$\begin{aligned} \tilde{\eta}_{(i,t)} &= 1 \quad \forall i \in (I^{dm} \setminus \tilde{I}^{dm}), t = \tau_i, \dots, (\tau_i + v_i - 1) \\ X_{(i,t)} &= 1 - \tilde{\eta}_{(i,t)} \quad \forall i \in (I^{dm} \setminus \tilde{I}^{dm}), t = \tau_i, \dots, (\tau_i + v_i - 1) \\ \tilde{\eta}_{(i,t)} &= 1 \quad \forall i \in \tilde{I}^{dm}, t = 1, \dots, (v_i - \tilde{v}_i) \\ X_{(i,t)} &= 1 - \tilde{\eta}_{(i,t)} \quad \forall i \in \tilde{I}^{dm}, t = 1, \dots, (v_i - \tilde{v}_i) \end{aligned} \quad (23')$$

Parameter \tilde{v}_i denotes the total time that compressor i has been under maintenance (since the start of the maintenance task) at the end of the previous scheduling horizon. In other words, $(v_i - \tilde{v}_i)$ represents the remaining time that compressor i has to be under maintenance in the current scheduling horizon. Parameter $\tilde{\eta}_{(i,t)}$ denotes if compressor i is under maintenance in time period t . For $\tilde{\eta}_{(i,t)} = 1$, the corresponding $X_{(i,t)}$ becomes zero.

Flexible maintenance tasks. In order to model these types of maintenance tasks, the following set of binary decisions variables has been introduced:

$$W_{(i,t)} = \begin{cases} 1, & \text{if the maintenance task in compressor } i \text{ begins in time period } t \\ 0, & \text{otherwise} \end{cases}$$

For compressors $i \in I^{fm} \subseteq I$ that are subject to flexible maintenance, the corresponding maintenance tasks should start within a given time window $t \in [\tau_i^{fs}, \tau_i^{ls}] \subseteq T$:

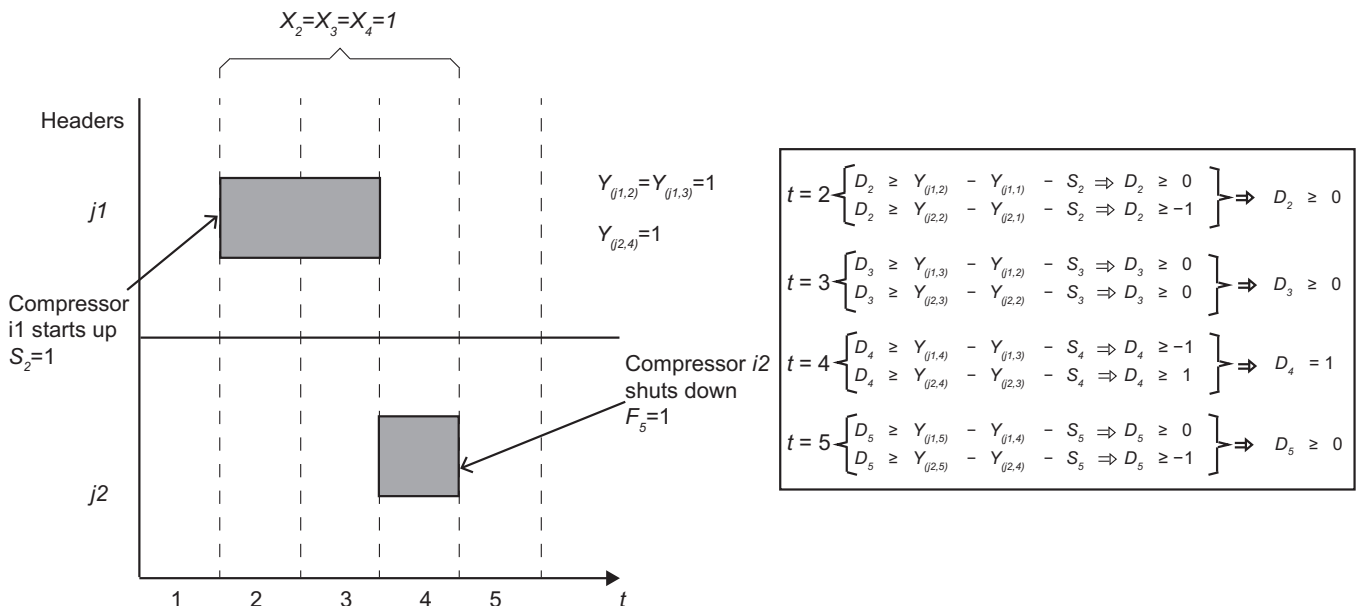

Fig. 6. Modeling of header changes through constraints (20).

$$\sum_{t=\tau_i^{es}}^{\tau_i^{ls}} W_{(i,t)} = 1 \quad \forall i \in I^{fm} \quad (24)$$

Notice that the latest starting time plus the duration of the maintenance task has to be lower or equal to the last time period of the scheduling horizon of interest (i.e., $(\tau_i^{ls} + v_i) \leq |T|$), in order to ensure that the maintenance task will be completed within the given scheduling horizon.

Hence, constraints (25) ensure the unavailability of compressor i throughout the duration of the flexible maintenance task v_i .

$$X_{(i,t)} + \sum_{t'=\max\{\tau_i^{es}, t-v_i+1\}}^{\min\{\tau_i^{ls}, t\}} W_{(i,t')} \leq 1 \quad \forall i \in I^{fm}, t = \tau_i^{es}, \dots, (\tau_i^{ls} + v_i - 1) \quad (25)$$

It should be clear that fixed maintenance tasks can be modeled as flexible maintenance tasks, if one includes them in set I^{fm} , and then defines $\tau_i^{es} = \tau_i$ and $\tau_i^{ls} = (\tau_i + v_i - 1)$. Also, it should be clear that an incomplete flexible maintenance task that started in the previous scheduling horizon, in the current scheduling horizon is a fixed maintenance task that can be modeled by constraints (23').

Maintenance tasks restrictions. In most industrial cases, the simultaneous maintenance of many compressors is expected to be undesired due to managerial or technical reasons. From a managerial point of view, having several compressors under maintenance at the same time significantly limits the operational flexibility in the presence of potential unexpected events. Moreover, the maintenance workforce may be limited, and therefore a maximum number of compressors (η_t) could be maintained simultaneously in every time period. This organizational aspect regarding maintenance tasks can be modeled by the following constraints:

$$\sum_{i \in (I^{dm} \cup I^{dm})} \tilde{\eta}_{(i,t)} + \sum_{\substack{i \in I^{fm} \\ \tau_i^{es} \leq t < (\tau_i^{ls} + v_i - 1)}} \sum_{t'=\max\{\tau_i^{es}, t-v_i+1\}}^{\min\{\tau_i^{ls}, t\}} W_{(i,t')} \leq \eta_t \quad \forall t \in T \quad (26)$$

6.3. Rolling horizon framework

The proposed mathematical model has been formulated in such a way so as to be used within a rolling horizon framework, if needed. Fig. 7 displays a representative algorithm for rolling horizon optimization. Briefly, in the rolling horizon scheme, an optimization problem is solved for a scheduling horizon of certain length (i.e., prediction horizon), and then the solution for just a part of that scheduling horizon (i.e., control horizon) is applied. A number of optimization problems is solved iteratively by moving forward the time horizon after each iteration. The key part of any rolling horizon approach is to update properly the current state of the system before the optimization of the prediction horizon of interest. For a detailed discussion on issues regarding the scheduling via rolling horizon approaches kindly refer to Kopanos and Pistikopoulos [16].

6.4. Explicit modeling of operations in the distillation columns

This work focuses on the operations optimization of the compressors in parallel. The discrete operations of the distillation columns, such as their on–off statuses, minimum run or shutdown times, and maintenance periods, are not considered in the paper because their times scales are much longer. However, the formulation to include them would be a straightforward extension of the proposed model. Similarly, the discrete operations of the liquefiers could also be readily included in the overall optimization framework.

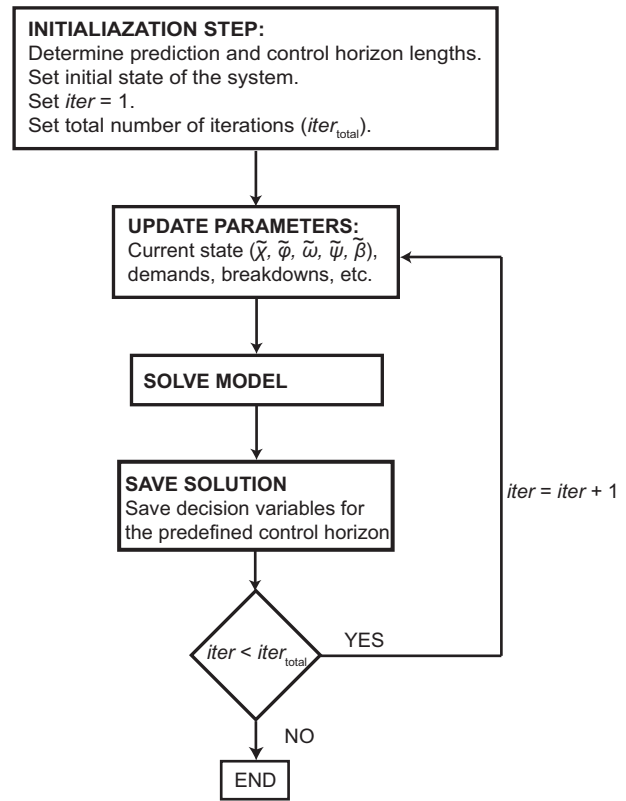

Fig. 7. A representative rolling horizon algorithm.

Table 1
Description of the case studies.

Case Study	Approach	Brief description
I	Deterministic	Simplified example of the industrial case
II	Deterministic	Industrial case with deterministic demand
III	Reactive (uncertainty)	Industrial case with demand fluctuations

7. Case studies

The industrial air separation plant of BASF in Ludwigshafen Germany is considered. The air separation plant consists of an air compressor station with eleven multi-stage centrifugal compressors working in parallel which supply three headers with compressed air. Oxygen and compressed air are the products of the industrial plant. The products cannot be acquired from external sources. There are five small compressors with throttling valves ($i \in I_s = \{i1, i2, i3, i4, i5\}$) and six large compressors with IGVs ($i \in I_b = \{i6, i7, i8, i9, i10, i11\}$). The first header $j1$ collects the compressed air for utilities in the industrial complex of BASF. The other two headers $j2$ and $j3$ are connected with two distillation columns $u1$ and $u2$, respectively. Table 2 gives the main operating data for the eleven compressors considered. These data have been derived from the thorough analysis of historical data of the industrial air separation plant. The costs for startup and shutdown of the compressors are estimated from Nguyen et al. [25]. The costs of the large compressors (i.e., $i6-i11$) are approximately 60% higher than those of the small compressors (i.e., $i1-i5$).

In this section, three case studies are addressed (see Table 1). First, a modified version of the industrial problem is considered

Table 2
Normalized compressor operating bounds on outlet mass flow and pressure (%).

	$i1$	$i2$	$i3$	$i4$	$i5$	$i6$	$i7$	$i8$	$i9$	$i10$	$i11$
ρ_i^{\min}	41.6	34.0	38.0	35.5	34.9	58.2	47.5	48.0	55.0	48.8	53.6
ρ_i^{\max}	58.5	55.7	55.2	55.8	56.5	88.4	87.6	83.7	83.4	87.0	87.7
π_i^{\min}	52.6	44.2	49.5	50.3	48.4	53.7	46.3	50.1	52.1	45.7	47.4
π_i^{\max}	68.9	64.8	70.0	59.8	62.6	64.9	69.3	69.3	66.5	69.2	69.8

Table 3
Case Study I: main parameters.

Symbol	Value	Unit	Comment
t	1	days	Duration of each time period
T	30	days	Length of time horizon
ω_i	6	days	Minimum run time
ψ_i	3	days	Minimum shutdown time
o_i	15	days	Maximum run time (for small only)
v_i	4	days	Duration of maintenance
σ_{O_2}	0.21	–	Volumetric fraction of O_2 in air
σ_{N_2}	0.78	–	Volumetric fraction of N_2 in air
μ_t	0.0984	m.u./kW h	Electricity cost per kW h
ε_i	1000	m.u./change	Cost for changing header
$u_{(O_2,t)}$	0.05	m.u./kg	Purchase price for O_2
$u_{(N_2,t)}$	0.01	m.u./kg	Purchase price for N_2

in order to highlight the main features of the proposed general optimization framework. In comparison with the original industrial case study, this illustrative case study (Case Study I) involves: (a) a smaller number of compressors; (b) nitrogen as an additional product; (c) a storage tank for nitrogen; (d) the possibility for purchasing the distillation products from external sources; and (e) demand profiles with more fluctuations in comparison to the industrial data of BASF. The second case study (Case Study II) considers the industrial problem of BASF under deterministic demand profiles for products. The last case study (Case Study III) deals with the reactive scheduling problem of the industrial case study of BASF. In this case, the demand profiles for products are not deterministic but they may vary from day to day, and therefore demand predictions are updated after every day period. A total scheduling horizon of 30 days, divided into one-day periods, is studied in all case studies. Several maintenance policies are considered in each of the case studies with the main purpose to show the important benefits of the simultaneous optimization of maintenance and operational tasks.

Finally, all given data and reported results are normalized and made dimensionless due to confidentiality reasons. All optimization problems have been solved in GAMS/CPLEX 11.1, under default configurations, in an Intel(R) Core(TM) i7-2600CPU @3.4 GHz with 8 GB RAM. A zero optimality gap has been imposed in all problem instances. Problem instances have been solved to zero optimality gaps, if not otherwise stated.

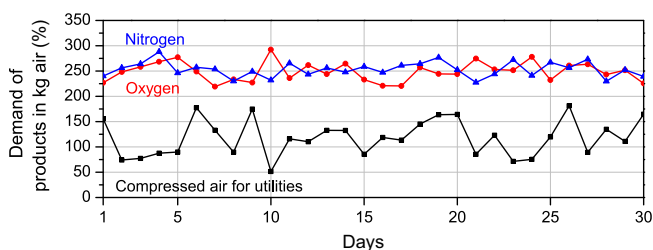

Fig. 8. Case Study I: normalized demand for products.

7.1. Case Study I: illustrative example

This illustrative example considers a modified version of the industrial air separation plant described above. More specifically, the air separation plant of this example consists of eight compressors $I := \{i1-i4, i8-i11\}$. There is no consideration of any initial configuration of the compressors (i.e., no history past). Table 3 provides the values of the main parameters of this example. A maximum run time $o_i = 15$ days for each small compressor is considered, while large compressors are not restricted regarding maximum run times. It is assumed that the demand for products (see Fig. 8) is known at the beginning of the planning horizon, and it is deterministic. The minimum storage level for each tank is 20% of its maximum capacity.

The outputs of the distillation columns are oxygen and nitrogen. It is assumed 100% conversion of the provided compressed air at the inlet of the distillation columns. Oxygen and nitrogen products can be either stored into their corresponding storage tanks or can be used directly to satisfy the demand. In addition, oxygen and nitrogen could be acquired from external sources under certain purchase prices. Purchase prices of products and electricity tariffs are assumed not to vary over time.

The illustrative example examines three different cases. The first baseline problem instance (Problem I.1) considers a fixed maintenance plan and a relatively high change header cost ($\varepsilon_i = 1000$ m.u./change). The second case (Problem I.2) is a slightly modified version of Problem I.1 with a lower change header cost ($\varepsilon_i = 250$ m.u./change). Finally, the third example (Problem I.3) addresses a flexible maintenance plan with the same change header costs as in Problem I.1.

Problem I.1. In this problem instance, the maintenance tasks are predefined. According to this fixed maintenance plan of the compressors, the maintenance tasks for compressors $i1, i3, i4, i8, i9$ and $i11$ have been pre-scheduled to start in days 1, 26, 8, 20, 12 and 15, respectively.

Fig. 9a displays the optimal compressors schedule (found by solving the proposed model) for the 30-day time horizon considered. The Gantt chart of Fig. 9a provides information regarding the active connections between compressors and headers as well as the operating status of the compressors. According to Fig. 9a, two compressors serve each header at most times. However, three compressors work in parallel on days where the demand for products is high. For example, when the demand for oxygen is high at day 10, one small and two large compressors ($i3, i9$ and $i11$) serve header $j3$ with compressed air. Moreover, three compressors serve header $j1$ when there is a peak in demand in compressed air for utilities at days 6, 9 and 26. The results show that two large compressors ($i9$ and $i10$) serve header $j1$ at day 1, when there is also a peak in the demand. When the demand in compressed air for utilities is low (such as in days 2, 3, 10, 23 and 24) only one large compressor ($i10$) serves header $j1$. In addition, Fig. 10 shows the load distribution for each compressor in each day. Small compressors are energy-efficient when they operate at maximum capacity, while large compressors are energy-efficient in a broader

(a) Problem I.1 (fixed maintenance and $\varepsilon_i = 1,000$).(b) Problem I.2 (fixed maintenance and $\varepsilon_i = 250$).(c) Problem I.3 (flexible maintenance and $\varepsilon_i = 1,000$).

Fig. 9. Case Study I: schedules for all problem instances.

operational area. For this reason, the large compressors accommodate the demand fluctuations by adjusting their mass flow rates while small compressors tend to operate at maximum capacity.

Fig. 11a presents the total compressed air supplied to each header for each time period. The mass flow of compressed air in header j1 is equal to the compressed air for utilities as shown in Fig. 8. Fig. 11b shows the compressed air load distribution proportion between the two distillation columns $u1$ and $u2$. As expected, $u2$ produces more than $u1$, due to the fact that $u2$ has a higher production capacity. Finally, purchase of nitrogen is reported in day 15. This is due to the fact that the demand for nitrogen cannot be satisfied because two large compressors are under maintenance on this day.

Problem I.2. A slightly modified version of Problem I.1 is considered with the aim to show how a variation in the cost for changing header could affect the optimal schedule. Here, the cost for changing header is lower than that of Problem I.1 ($\varepsilon_i = 250$ m.u./change). All remaining data are the same.

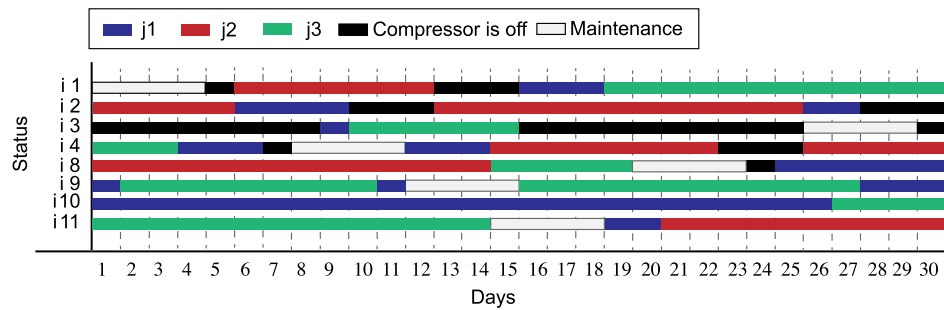
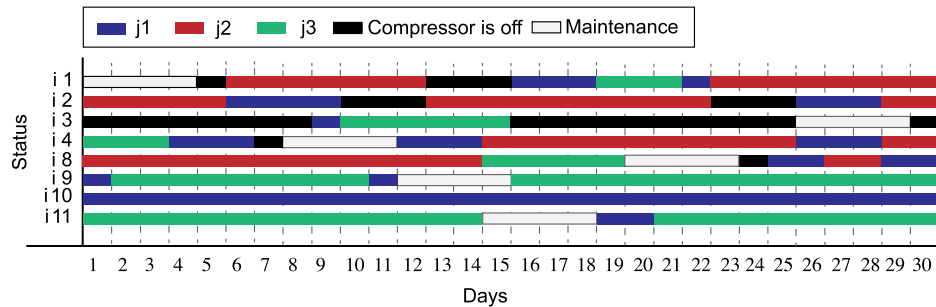
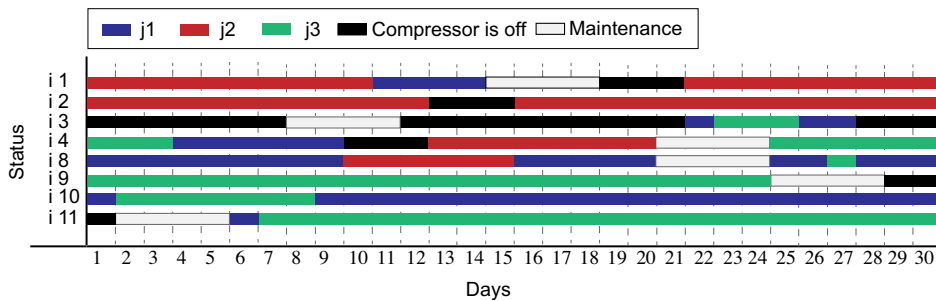
Fig. 9b shows the optimal schedule for the compressors. As expected, in the optimal schedule of this problem instance there are more header changes than in that of Problem I.1. More

specifically, there are 16 header changes in Problem I.2 and 12 header changes in Problem I.1. Due to the different associated costs for changing header, the total changing-header cost in Problem I.2 (4000 m.u.) is lower than that of Problem I.1 (12,000 m.u.). Nevertheless, according to Table 5, the total cost without considering the change header cost (see obj^* column) did not change much between the two problem cases. Another interesting observation here is that the results show that the computational time decreases significantly, if the header change cost increases. This observed trend seems reasonable since high header change costs, could restrict the operational flexibility and as a consequence potentially decrease the solution search space. Finally, similarly to Problem I.1, there are purchases of nitrogen in day 15, because the air separation plant cannot meet the demand for nitrogen since two large compressors are under maintenance on this day.

Problem I.3. In contrast to the fixed maintenance plan of the two previous problem instances, here a flexible maintenance plan for the compressors is considered. This means that the maintenance tasks have not been pre-scheduled, but earliest and latest starting times for them are provided (see Table 4). The change header cost is equal to that in Problem I.1. The aim of this problem instance is

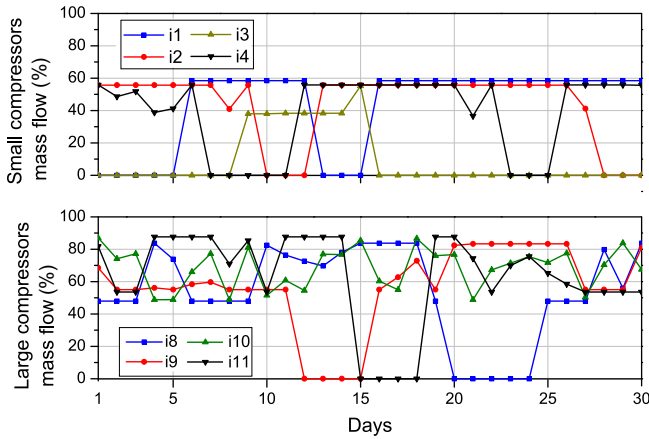

Fig. 10. Problem I.1: normalized load of compressors.

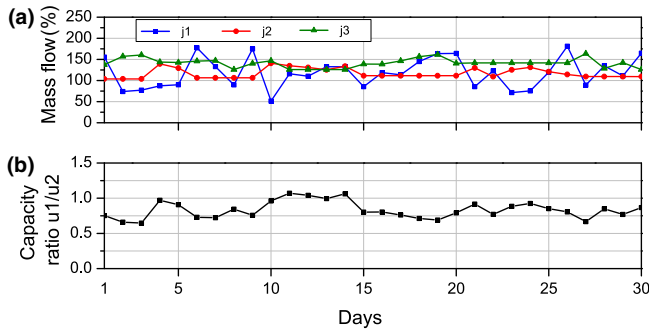

Fig. 11. Case Study I.1: (a) total compressed air supplied to each header, and (b) production capacity ratio of column $u1$ and $u2$.

to demonstrate that a better schedule (in terms of total cost) can be obtained if maintenance and operational tasks for compressors are optimized simultaneously.

The computational results for all problem instances of Case Study I can be found in Table 5. Due to the flexible maintenance tasks, there are 124 more binary variables in this example problem compared to those in the previous problem instances. This fact results in an increase in the computational time. Fig. 9c displays the optimal compressors schedule for Problem I.3. Once again, notice that the maintenance plan is an output of the optimization. The results show that the total cost is reduced by 10% compared to that of Problem I.1, which is principally due to the flexible maintenance policy. Fig. 12a shows the aggregated total cost of Problems I.1 and I.3 per each day.

In Problem I.3, maintenance tasks are scheduled in such a way that the number of startups and shutdowns is decreased in comparison with the schedules of the previous problem instances. Fig. 12b shows that the power consumption, startup and shutdown costs are reduced when flexible maintenance tasks are considered. The fixed maintenance plan case can be considered as the upper bound for the flexible maintenance plan case. The total change header cost in Problem I.3 (eleven header changes) is approximately the same as in Problem I.1 (twelve header changes). At this point, recall that purchases of nitrogen have been reported at day 15 in Problems I.1 and I.2, due to the fact that the facility could not satisfy the demand because two large compressors are under pre-scheduled maintenance during this day. However, in Problem I.3 the maintenance tasks have been scheduled optimally in such a way that the demand for products could be met without the need of any product purchases from external sources. Therefore, this

Table 4

Problem I.3: earliest and latest starting times for flexible maintenance tasks (in days).

	i1	i2	i3	i4	i8	i9	i10	i11
τ_i^{es}	1	-	1	5	10	10	-	1
τ_i^{ls}	15	-	26	25	25	25	-	26

Table 5

Case Study I: computational results for all problem cases.

	# eqns	# bin vars	# cont vars	# nodes	CPU s	Obj val (m.u.)	obj* (m.u.)
Problem I.1	8574	1770	2580	9742	293	90.98	86.64
Problem I.2	8574	1770	2580	321,355	4903	87.67	86.51
Problem I.3	8695	1894	2580	139,173	10,695	81.92	78.25

problem instance has demonstrated clearly the significant benefits of the simultaneous optimization of operational and maintenance tasks (i.e., flexible maintenance policy).

7.2. Case Study II: industrial case study – deterministic scheduling

Here, the proposed optimization-based framework is applied in a deterministic industrial case study of the air separation plant of BASF in Ludwigshafen, Germany. Oxygen and compressed air for utilities are the products, and their normalized demand profiles are displayed in Fig. 13. The cost of changing header is equal to 250 m.u./change and purchases of oxygen are not allowed. Small and large compressors could operate for maximum 20 and 60 consecutive days respectively, apart from $i5$ which can operate for a maximum of 50 consecutive days. In addition, large compressors have a minimum run time of six days while $i1, i2, i3, i4, i5$ have minimum run times equal to five, six, seven, six and five days respectively.

All the related past data that fully describe the condition of the compressors at the beginning of the scheduling horizon (i.e., $t = 0$)

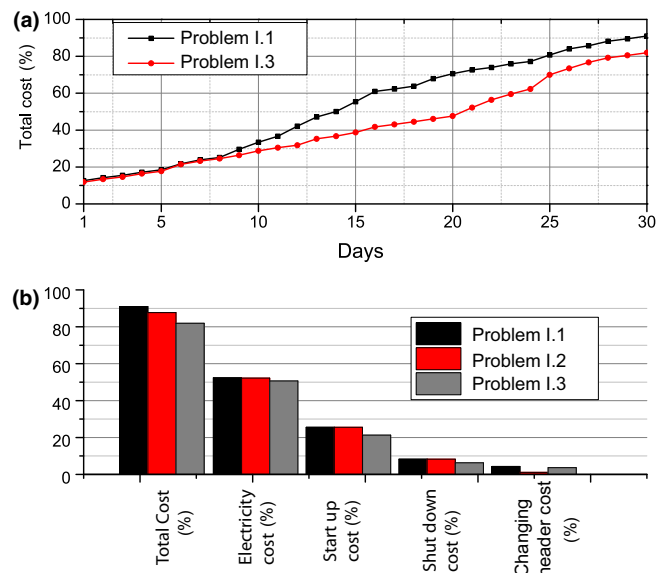

Fig. 12. Case Study I: (a) aggregated normalized objective value for Problems I.1 and I.3 and (b) normalized total cost breakdown for all problem instances.

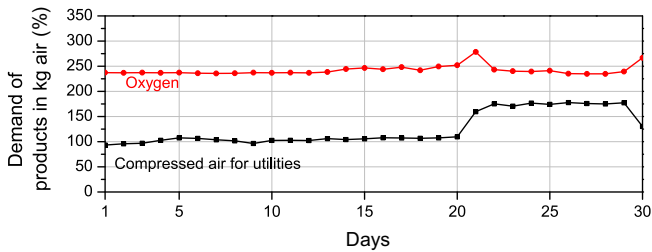

Fig. 13. Case Study II: normalized demand for products.

Table 6

Case Study II: initial condition (i.e., $t = 0$) for all compressors.

	$i1$	$i2$	$i3$	$i4$	$i5$	$i6$	$i7$	$i8$	$i9$	$i10$	$i11$
Header	–	$j1$	–	–	$j2$	$j2$	–	$j1$	–	$j3$	$j3$
$\hat{\omega}$	0	6	0	0	25	22	0	10	0	36	40
$\hat{\psi}$	6	0	18	2	0	0	30	0	29	0	0

can be found in Table 6. More specifically, Table 6 contains information regarding: (i) the active compressor-to-header connection ($\hat{\phi}_{(i,j)}$); (ii) the total duration that each compressor has been operating from its last startup ($\hat{\omega}_i$); and (iii) the total duration that each compressor has not been operating since its last shutdown ($\hat{\psi}_i$). For instance, at the beginning of the scheduling horizon, compressor $i2$ is connected to header $j1$ and it has been operating for six time periods (not necessarily serving $j1$ in all of these periods) since its last startup. Also, at the beginning of the scheduling horizon, compressor $i7$ has not been operating for 30 time periods since its last shutdown.

In this case study, three different maintenance policies are considered: (i) fixed maintenance plan (Problem II.1); (ii) flexible maintenance plan through the simultaneous optimization of operational and maintenance tasks (Problem II.2); and (iii) flexible maintenance plan considering maintenance workforce limitations (Problem II.3). Table 7 provides the given data for the corresponding maintenance policy for each case.

Table 8 presents the computational results for the problem instances of Case Study II. The introduction of additional binary variables related to flexible maintenance tasks (Problems II.2 and II.3) makes the resulting scheduling problem harder to solve compared to the fixed maintenance plan (Problem II.1). In general, the more constrained the optimization problem, the more computationally expensive its solution is expected to be.

Problem II.1. Fig. 14a displays the optimal schedule for Problem II.1. It can be observed that nine compressors are used to cover the demand over the 30 days, and compressors $i1$ and $i3$ do not operate in any time period. Also, there are no header changes in this problem instance. It should be noted that the initial compressor conditions influence the obtained schedule. For instance, compressor $i10$, which has been operating continuously for 36 days before the beginning of the scheduling horizon, shuts down at the

Table 7

Case Study II: information of maintenance tasks of the compressors.

Problems	Parameter	$i1$	$i2$	$i3$	$i4$	$i5$	$i6$	$i7$	$i8$	$i9$	$i10$	$i11$
Problem II.1	τ_i	26	–	–	7	15	2	–	–	22	–	–
Problem II.1–3	v_i	5	–	–	3	5	3	–	–	3	–	–
Problems II.2 and II.3	τ_i^{cs}	1	–	–	1	1	1	–	–	1	–	–
Problems II.2 and II.3	τ_i^{ls}	26	–	–	28	25	28	–	–	28	–	–

Table 8

Case Study II: computational results for all cases.

	# eqns	# bin vars	# cont vars	# nodes	CPU s	Obj val (m.u.)
Problem II.1	11,545	2310	3150	1704	139	55.61
Problem II.2	11,683	2444	3150	58,626	7721	54.65
Problem II.3	11,817	2594	3150	82,517	14,000	54.65

beginning of time period 25 because it reaches its maximum run time of 60 days. Fig. 15 shows the normalized load distribution for each compressor for every time period. Similarly to Case Study I, small compressors usually operate close to (or exactly at) their maximum flow rate, while the large compressors change their flow rate to a larger range to cover the demand fluctuations. This result was expected because small compressors are controlled with inlet throttling valves while large compressors with inlet guide vanes. In practice, the throttling of the small compressors makes them inefficient in lower mass flows. This output was observed from the past operation of the plant which shows a similar operational strategy. Therefore, despite the fact that the regression models used do not explicitly assess the performance of each compressor, they implicitly captured the efficiency of the compressors. Indeed, the small compressors operate close to maximum in the industrial air separation plant studied. In addition, a number of large compressors, such as $i6$ and $i10$, tend to operate at a fixed mass flow rate while other large compressors with better efficiency in a larger range cover the demand variations.

Problem II.2. Fig. 14b gives the schedule for the unconstrained flexible maintenance case. Due to the simultaneous optimization of maintenance and operational tasks, the maintenance tasks have been scheduled differently from Problem II.1 in such a way that the total cost has been decreased by 1.8% in comparison to that in Problem II.1 (see Table 8). Also, all maintenance tasks have been completed before day 21, where demand for products increases significantly. In this problem instance, there are several time periods where maintenance tasks take place simultaneously. For example, from day 1 to 3, three maintenance tasks are performed simultaneously, and in day 4 and 5, two maintenance tasks take place at the same time. As already discussed in Section 6.2, the simultaneous maintenance of many compressors may give rise to managerial or technical issues. For this reason, a constrained flexible maintenance policy (Problem II.3) is considered next, in order to avoid simultaneous maintenance tasks.

Problem II.3. In this constrained flexible maintenance case, at most one maintenance task can take place in every time period (i.e., $\eta_t = 1$). Fig. 14c displays the optimal schedule of this problem instance. As it can be seen from Table 8, the total cost of Problem II.3 is the same with that of Problem II.2. This is because the schedule did not change much from Problem II.2, since the only difference here is that the maintenance tasks in compressors $i1$ and $i4$ have been right-shifted. It should be clear that these two changes

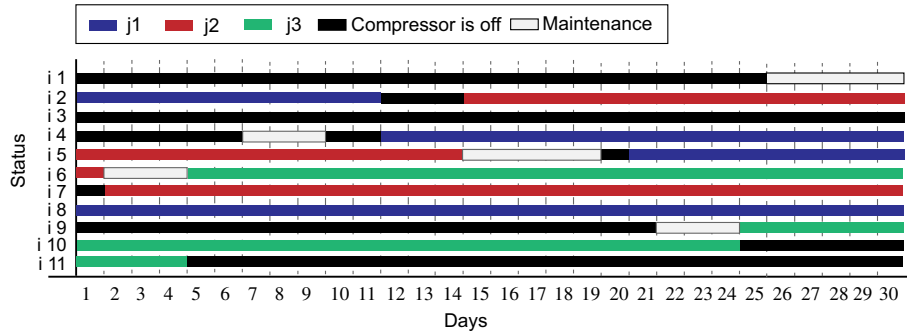

(a) Problem II.1 (fixed maintenance).

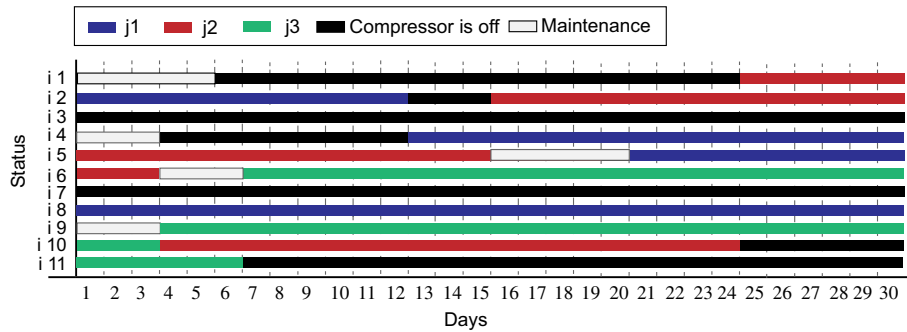

(b) Problem II.2 (unconstrained flexible maintenance).

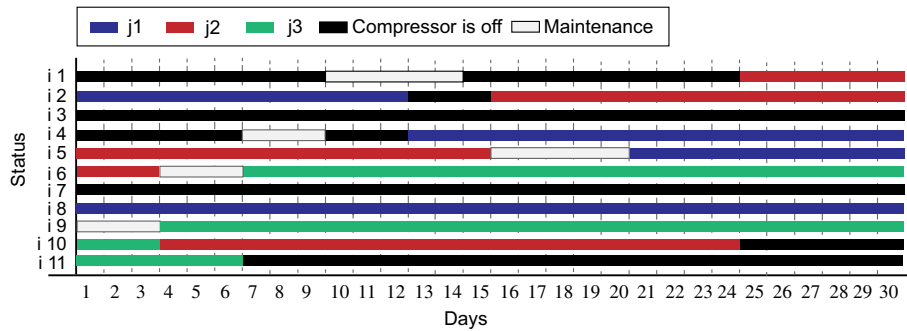

(c) Problem II.3 (constrained flexible maintenance $\eta_t = 1$).

Fig. 14. Case Study II: schedules for all problem instances.

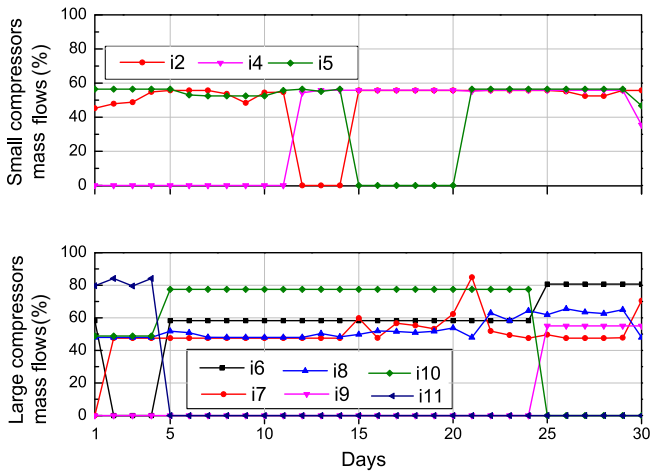

Fig. 15. Case Study II: normalized load of compressors for Problem II.1.

did not affect the total cost since they do not add any cost, and the rest of the schedule is the same as that in Problem II.2. Although Problems II.2 and II.3 generate the same total cost, Problem II.3 gives a better schedule in terms of flexibility and managerial perspective, since maintenance tasks are distributed more uniformly over the scheduling horizon of interest.

Finally, Fig. 16a provides a comparison for the aggregated normalized total cost between Problems II.1 and II.3. Fig. 16b shows the normalized total cost breakdown for all problem instances (Problem II.2 is exactly the same with Problem II.3). Similarly to Case Study I, it is observed that startup and power consumption costs decrease under a flexible maintenance policy (i.e., Problems II.2 and II.3). More specifically, in these cases power consumption cost has been reduced by 0.62%, and startup cost declines by 7.70% in comparison with those in Problem II.1. Overall, it has been demonstrated that the simultaneous optimization of maintenance and operational tasks could provide better solutions and decrease the total cost.

7.3. Case Study III: industrial case study – reactive scheduling

In this part, the reactive scheduling problem in a case study of the air separation plant in BASF is addressed. The main aim of this problem instance is to show how the proposed mathematical framework can cope successfully with a real-life case study under the presence of demand uncertainty. Similar to the previous case study, oxygen and compressed air are the distillation column products, change header cost is equal to 250 m.u./change, and purchases of oxygen are not allowed. In this case study, demand for products is not deterministic but instead may fluctuate over time. For this reason, the demand profiles are updated after each day period through forecasting for a given prediction horizon. For the 30-day scheduling horizon considered, Fig. 17 shows the actual normalized demand profile for oxygen and compressed air for utilities. The initial condition for all compressors is the same as in Case Study II (see Table 6). Here, some compressors follow a fixed maintenance policy and others a flexible maintenance policy. Compressors *i9* and *i11* have been pre-scheduled for maintenance in days 20 and 15, respectively. Compressors *i2* and *i6* are under flexible maintenance, and their corresponding maintenance tasks must start in days 1 and 15, respectively. The duration for each maintenance task is equal to three days. Maximum run times for compressors are the same as in Case Study II.

The reactive scheduling problem has been solved via a rolling horizon approach, as displayed in Fig. 7. A time period is equal to one day. A prediction horizon equal to 21 time periods, and a single-period control horizon have been used. In other words, there is a new demand prediction for the following 21 days after every day. A total number of 30 iterations has been solved. An iteration represents a scheduling problem which employs a prediction horizon of 21 days. A time limit of 1800 CPU s was set for each iteration. The computational time for every iteration can be found in Fig. 18. On average, solutions are obtained in low computational times. Negligible optimality gaps have been reported for iterations 20–22, where the imposed time limit was reached. As discussed in Kopanos and Pistikopoulos [16], it should be clear that longer prediction horizons result in bigger mathematical model sizes, and as

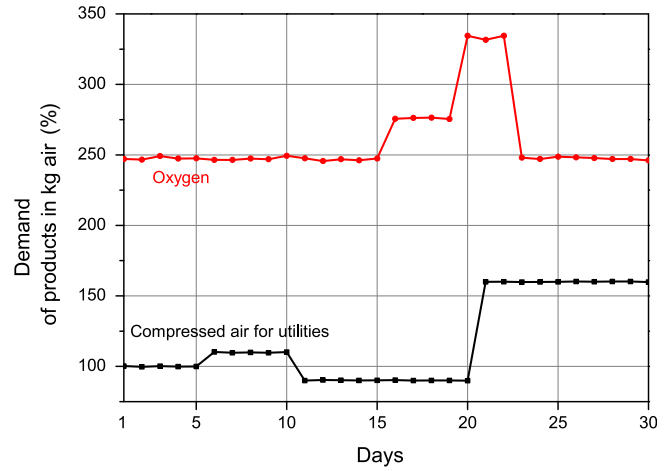

Fig. 17. Case Study III: normalized demand for products (actual values).

a consequence the necessary computational time will probably increase too.

At the beginning of each time period, a scheduling problem for the next 21 time periods (i.e., the prediction horizon) is solved with updated information regarding the current state of the overall system and the demand for products. Only the solution of the first time period of the current prediction horizon is applied. In this problem instance, an unexpected breakdown of compressor *i5* in the second time period is considered. Fig. 19 shows an example of how the overall schedule (for the 30-day horizon considered) is constructed through the solutions obtained in each iteration. The last Gantt chart gives the implemented schedule. The compressors that do not operate in any iteration are not included in Fig. 19.

The normalized load distribution of each compressor is given in Fig. 20. It shows that compressors *i3*, *i4*, and *i9* remain idle during the 30-day scheduling horizon considered. It should be noted here that it is known that compressor *i3* is the most energy-inefficient compressor, and the results of all case studies give a clear evidence of it, since the obtained solutions preferred to keep shutdown or operate it in limited capacity. At this point, if we consider the case that the demand for products for all 30 time periods is known with

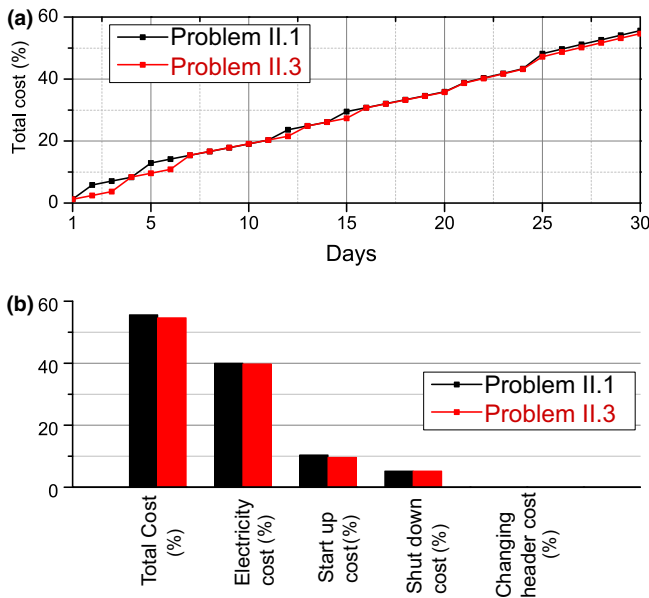

Fig. 16. Case Study II. Problems II.1 and II.3: (a) aggregated normalized objective value and (b) normalized total cost breakdown.

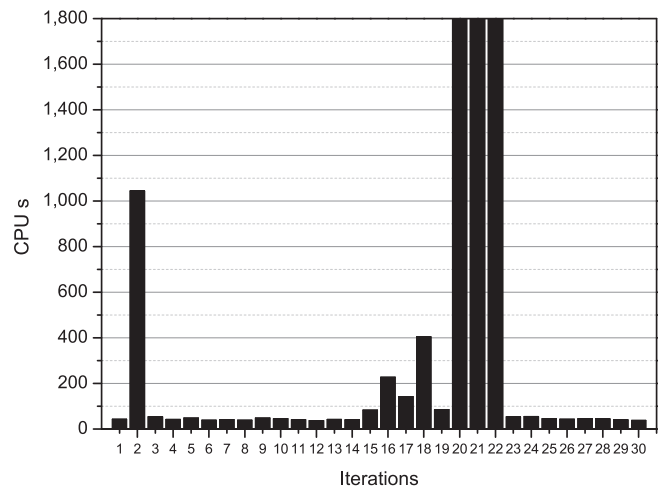

Fig. 18. Case Study III: computational CPU s time for each iteration.

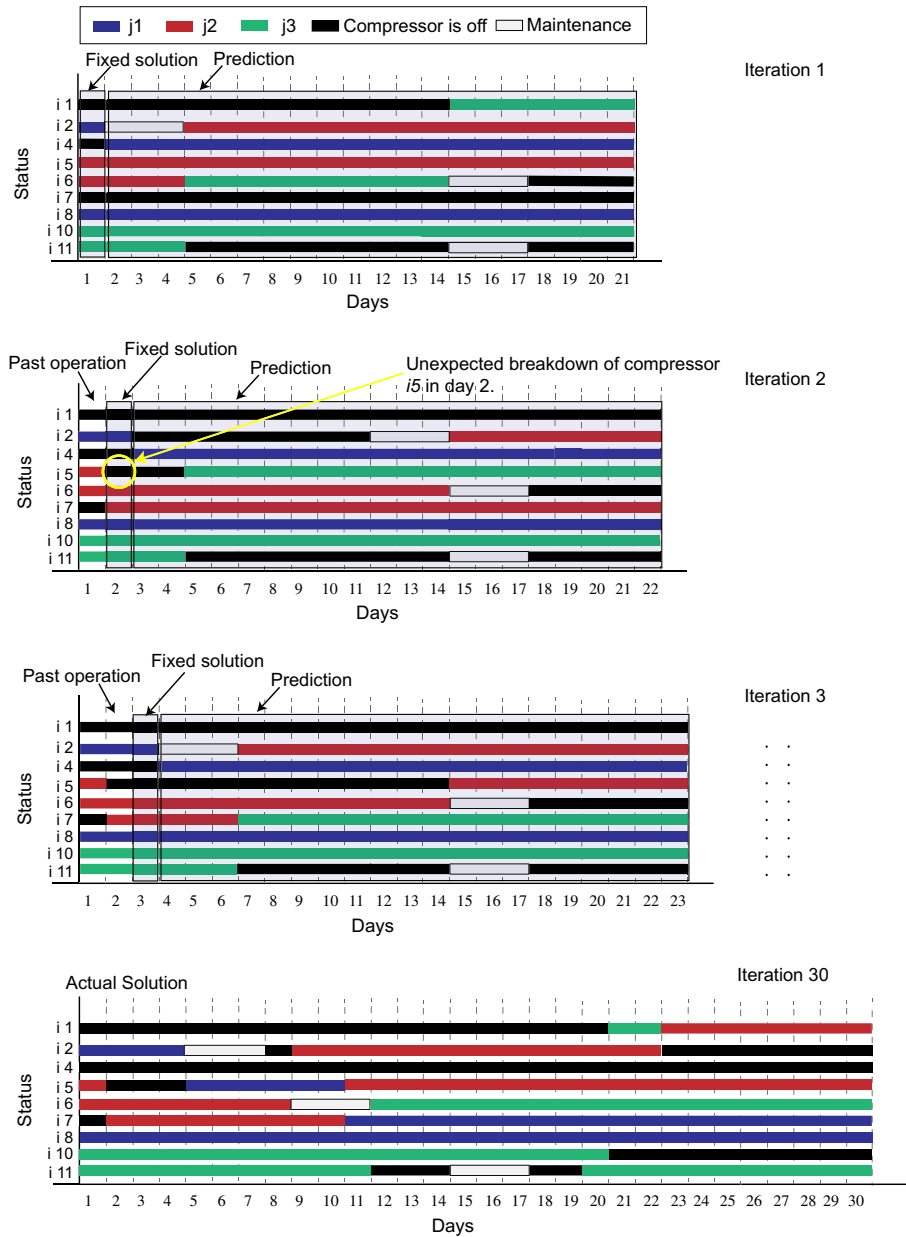

Fig. 19. Case Study III: schedule generation via rolling horizon.

certainty at the beginning of the time horizon of interest (i.e., so-called perfect information case), one could solve the deterministic scheduling problem for the whole scheduling horizon at once. The perfect information solution is the best solution that one could obtain. However, in practice, this solution is impossible to be found due to the uncertainty in the demand forecasting. The aggregated total cost of the perfect information case and the solution derived by the rolling horizon approach are shown in Fig. 21. The results show that the rolling horizon solution is 11% worse than that of the perfect information case. It should be clear to the reader that the obtained solution could be improved, if the forecasting accuracy is improved and the length of the prediction horizon increases. However, in practice as the length of the prediction horizon increases, the forecasting accuracy naturally decreases. Overall, through this problem instance it has been shown the applicability of the proposed mathematical framework to deal with relevant scheduling problems in dynamic production environments.

8. Conclusions

In this work, a general mathematical framework for the simultaneous optimization of maintenance and operational tasks of compressors in air separation plants has been presented. A distinctive feature of the proposed approach is that the power consumption in compressors is expressed by regression functions. The suggested approach considers operating constraints for compressors, several types of maintenance policies (i.e., runtime-based, fixed, and flexible) as well as managerial aspects regarding maintenance decisions. Power consumption, startup, shutdown and change header costs for the compressors in tandem with their maintenance tasks are optimized. The case studies solved have demonstrated that the simultaneous optimization of maintenance and operational tasks of compressors (i.e., flexible maintenance case) favors the generation of better solutions in terms of total costs in comparison to the predefined maintenance alternative (fixed maintenance case). According to the case studies, this is

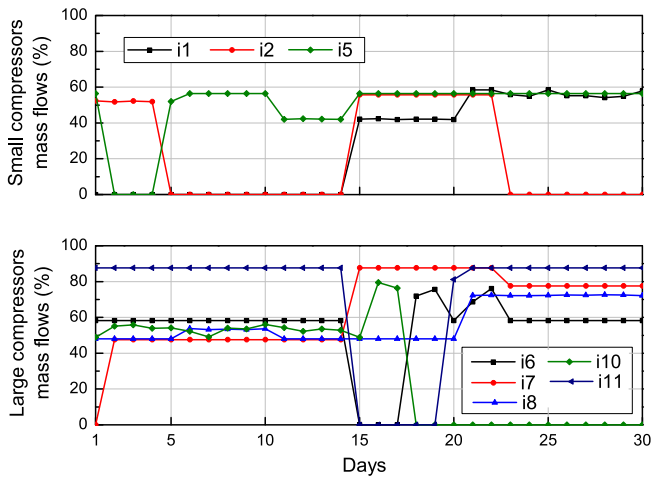

Fig. 20. Case Study III: normalized mass flows of small and large compressors.

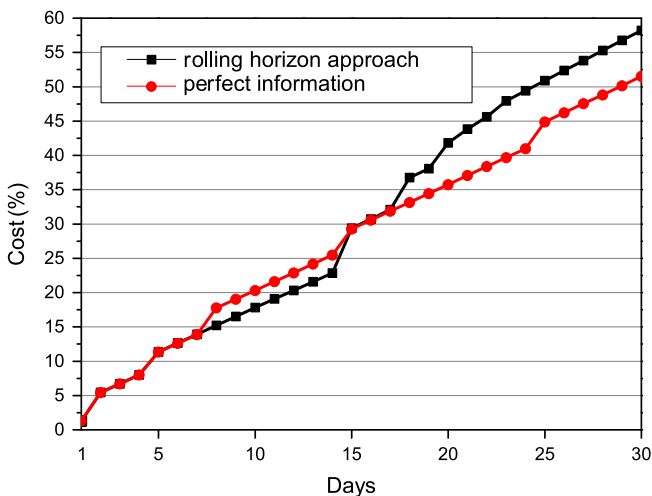

Fig. 21. Case Study III: aggregated normalized objective value for the rolling horizon and perfect information solution.

mainly due to the fact that the flexible maintenance policy results in reduced startup, shutdown and power consumption costs.

Ongoing research involves the more thorough study and optimization of maintenance tasks. More specifically, in compressors, the most prevalent deterioration problem is fouling, which has a significant impact on the performance of the compressor. The performance of the compressor due to fouling can be recovered by on-line or off-line washing (maintenance) [26]. Therefore, similar to gas turbines [24], the study of condition-based maintenance in compressors is of great importance, and indeed it constitutes a main subject of our current research activities.

Acknowledgments

Financial support from the Marie Curie FP7-ITN project "Energy savings from smart operation of electrical, process and mechanical

equipment – ENERGY-SMARTOPS", Contract No: PITN-GA-2010-264940 is gratefully acknowledged. The authors also acknowledge the financial support from the Engineering and Physical Sciences Research Council (EPSRC) under the Research Project EP/G059071/1. The authors finally acknowledge BASF Ludwigshafen for providing the case study.

References

- [1] Saidur R, Rahim NA, Hasanuzzaman M. A review on compressed-air energy use and energy savings. *Renew Sustain Energy Rev* 2010;14(4):1135–53.
- [2] US Department of Energy. Improving Compressed Air System Performance, 2003.
- [3] Xenos DP, Ciccotti M, Kopanos GM, Bouaswaig AEF, Kahrs O, Martinez-Botas RF, Thornhill NF. Optimization of a network of compressors in parallel: Real Time Optimization (RTO) of compressors in chemical plants – An industrial case study. *Appl Energy* 2015;144:51–63.
- [4] Sood AK, Funk GL, Delmastro AC. Dynamic optimization of a natural gas pipeline using a gradient search technique. *Int J Control* 1971;14(6):1149–57.
- [5] Marques D, Morari M. On-line optimization of gas pipeline networks. *Automatica* 1988;24(4):455–69.
- [6] Mahlke D, Martin A, Moritz S. A mixed integer approach for time-dependent gas network optimization. *Optim Methods Softw* 2010;25(4):625–44.
- [7] Uraikul V, Chan CW, Tontiwachwuthikul P. A mixed-integer optimization model for compressor selection in natural gas pipeline network system operations. *J Environ Inform* 2004;3(1):33–41.
- [8] Nguyen HH, Chan CW. Applications of artificial intelligence for optimization of compressor scheduling. *Eng Appl Artif Intell* 2006;19(2):113–26.
- [9] van den Heever SA, Grossmann IE. A strategy for the integration of production planning and reactive scheduling in the optimization of a hydrogen supply network. *Comput Chem Eng* 2003;27(12):1813–39.
- [10] Camponogara E, Nazari LF, Meneses CN. A revised model for compressor design and scheduling in gas-lifted oil fields. *IIE Trans* 2012;44(5):342–51.
- [11] Han I-S, Han C, Chung C-B. Optimization of the air- and gas-supply network of a chemical plant. *Chem Eng Res Des* 2004;82(A10):1337–43.
- [12] Rong A, Lahdelma R. An efficient linear programming model and optimization algorithm for trigeneration. *Appl Energy* 2005;82(1):40–63.
- [13] Thorin E, Brand H, Weber C. Long-term optimization of cogeneration systems in a competitive market environment. *Appl Energy* 2005;81(2):152–69.
- [14] Kopanos GM, Georgiadis MC, Pistikopoulos EN. Energy production planning of a network of micro combined heat and power generators. *Appl Energy* 2013;102:1522–34.
- [15] Zhuang X, Xia X. Optimal operation scheduling of a pumping station with multiple pumps. *Appl Energy* 2013;104:250–7.
- [16] Kopanos GM, Pistikopoulos EN. Reactive scheduling by a multiparametric programming rolling horizon framework: a case of a network of combined heat and power units. *Ind Eng Chem Res* 2014;53(11):4366–86.
- [17] Xenos DP, Ciccotti M, Bouaswaig AEF, Thornhill NF, Martinez-Botas RF. Modelling and optimization of industrial centrifugal compressor stations employing data-driven methods. *Proceedings of ASME Turbo Expo 2014*, June 16–20, Düsseldorf, Germany, 2014.
- [18] Brooks DG, Carroll SS, Verdini WA. Characterizing the domain of a regression-model. *Am Stat* 1988;42(3):187–90.
- [19] Vinson DR. Air separation control technology. *Comput Chem Eng* 2006;30:1436–46.
- [20] Zhu Y, Legg S, Laird CD. Optimal operation of cryogenic air separation systems with demand uncertainty and contractual obligations. *Chem Eng Sci* 2011;66(5):953–63.
- [21] Ierapetritou MG, Wu D, Vin J, Sweeney P, Chigirinskiy M. Cost minimization in an energy-intensive plant using mathematical programming approaches. *Ind Eng Chem Res* 2002;41(21):5262–77.
- [22] Karwan MH, Kebliis MF. Operations planning with real time pricing of a primary input. *Comput Oper Res* 2007;34(3):848–67.
- [23] Mitra S, Grossmann IE, Pinto JM, Arora N. Optimal production planning under time-sensitive electricity prices for continuous power-intensive processes. *Comput Chem Eng* 2012;38:171–84.
- [24] Li YG, Nilkitsaranont P. Gas turbine performance prognostic for condition-based maintenance. *Appl Energy* 2009;86(10):2152–61.
- [25] Nguyen HH, Uraikul V, Chan CW, Tontiwachwuthikul P. A comparison of automation techniques for optimization of compressor scheduling. *Adv Eng Softw* 2008;39(3):178–88.
- [26] Aretakis N, Roumeliotis I, Doumouras G, Mathioudakis K. Compressor washing economic analysis and optimization for power generation. *Appl Energy* 2012;95:77–86.