

Evaluating biomass energy strategies for a UK eco-town with an MILP optimization model

James Keirstead^{a,*}, Nouri Samsatli^b, A. Marco Pantaleo^c, Nilay Shah^b

^a*Department of Civil and Environmental Engineering, Imperial College, London, UK,
SW7 2AZ*

^b*Department of Chemical Engineering, Imperial College, London, UK, SW7 2AZ*

^c*Centre for Environmental Policy, Imperial College, London, UK, SW7 2AZ*

Abstract

Recent years have seen a marked interest in the construction of eco-towns, showcase developments intended to demonstrate the best in ecologically-sensitive and energy-efficient construction. This paper examines one such development in the UK and considers the role of biomass energy systems. We present an integrated resource modelling framework that identifies an optimized low-cost energy supply system including the choice of conversion technologies, fuel sources, and distribution networks. Our analysis shows that strategies based on imported wood chips, rather than locally converted forestry residues, burned in a mix of ICE and ORC combined heat and power facilities offer the most promise. While there are uncertainties surrounding the precise environmental impacts of these solutions, it is clear that such biomass systems can help eco-towns to meet their target of an 80% reduction in greenhouse gas emissions.

Key words: urban energy systems, biomass to energy, optimization, modelling, combined heat and power

*Corresponding author. Tel: +44 (0)20 7594 6010.

Email addresses: j.keirstead@imperial.ac.uk (James Keirstead),
n.samsatli@imperial.ac.uk (Nouri Samsatli), a.pantaleo@imperial.ac.uk (A. Marco
Pantaleo), n.shah@imperial.ac.uk (Nilay Shah)

1. Introduction

Cities account for approximately two-thirds of the world's primary energy consumption and 71% of global fossil-fuel related direct greenhouse gas emissions [1]. Therefore to ensure that cities maintain their vital social and economic functions, while mitigating global climate change, there is a need to develop urban energy systems that are more efficient and emit less carbon dioxide.

One option is to switch from fossil fuels to renewable energy sources such as wind, solar or biomass. This is typically achieved with national or regional policy initiatives. For example, the European Union has issued a directive which sets an EU-wide target of providing 20% of final energy consumption from renewable sources by 2020. The target is then broken down by member state: the UK, for example, has agreed to increase its renewable energy mix from 1.3% in 2005 to 15% by 2020 [2]. Urban environments are recognized as having an important role to play in delivering these goals. Articles 12.3 and 12.4 of the directive oblige member states to “consider” the use of renewables “when planning, designing, building and refurbishing industrial or residential areas” and to “require the use of minimum levels of energy from renewable sources in new or refurbished buildings”. A practical example of such a policy in the UK is the *Code for Sustainable Homes*, “an environmental assessment method for rating and certifying the performance of new homes”. This standard recognizes biomass energy systems, from single household boilers to district combined heat and power (CHP) systems, as “low or zero carbon technologies” integral to achieving high performance levels [3].

However, urban biomass energy systems pose a number of practical challenges including the use of specialist technologies, a range of alternative supply chains, and local air pollution impacts. This paper explores these trade-offs in the case of a UK eco-town and demonstrates a software tool

that evaluates alternative technological options to identify an optimal (low cost) urban biomass energy system. The issues that need to be considered in such a model and the eco-town case study are presented in Section 2. An overview of the software tool and the input data is then given in Section 3, before the results are described in Section 4. In the concluding discussion, we consider the implications of the results for the specific eco-town case as well as urban biomass energy systems more generally.

2. Background

This section highlights the diversity of urban biomass energy systems and key findings from the literature. It then introduces an eco-town case study to be used in the subsequent modelling. Note that our focus is on biomass for heat and power applications; we have not examined biofuels for urban transport.

2.1. Characteristics of urban biomass energy systems

There are several options to produce heat and power from biomass and these can be generally classified according to criteria such as biomass type, technology type and size, and the degree of decoupling between biomass treatment and conversion processes [4]. When integrating bioenergy into urban areas, the specific concerns are the availability of space for biomass storage and pre-treatment, the emission levels of bioenergy conversion processes, and transport issues including the logistics and costs of biomass supply. These barriers are mainly caused by the low energy density of biofuels, which require additional conditioning processes and consequently result in energy conversion efficiencies lower than what could be achieved via fossil fuel routes. Scarcity and competing alternative uses of biomass feedstocks are also a concern.

Despite these obstacles, bioenergy routes offer potentially high overall energetic, economic and environmental performance in urban areas due to

the aggregation of demand and typically high energy costs. Unfortunately the proximity of the energy conversion plants to the load can be a disadvantage since the resulting emissions are also close to people. As power plants are often far from urban centres, new local plants can have a major impact on local air quality [5, 6, 7]. On the other hand, the effects of converting heating systems from electricity or gas-fired boilers to pellet heating systems have also been investigated, showing that conversion from electrical heating to pellets does not significantly affect air quality [8].

Urban bioenergy solutions therefore require a trade-off between centralized large plants and distributed small plants: the benefits of the former being high conversion efficiencies, low emission levels and low specific investment and operational costs; while the latter are advantageous due to reduced space requirements, simplified logistics and transport, and ease of plant location. For this reason, several studies have aimed to optimize the location and size of biomass CHP plants on the basis of technical and economic factors [9, 10, 11, 12]. For example, a multi-criteria decision analysis methodology was applied to the Metropolitan Borough of Kirklees in Yorkshire, UK, to compare small-scale renewable energy schemes with large-scale alternatives. The results indicated that small-scale schemes were the most sustainable, despite large-scale schemes being more financially viable [13].

The most promising urban biomass energy systems are therefore often characterized by high-density biofuel feedstocks, clean conversion technologies and combined heat and power systems. However local air pollution and the relative costs and performance of alternative system configurations must be considered.

2.2. The eco-town case study

This paper presents an optimization model to evaluate alternative urban biomass energy systems. To illustrate its use, we have chosen a case study based on a proposed “eco-town” development in the UK. Given rising

demand for housing as well as substantial questions about how the building sector might contribute to national climate change and energy policy goals, the UK government has promoted eco-towns as an opportunity to drive innovation and to demonstrate how these policy goals might be jointly achieved. It has been suggested that the headline targets for these developments should be an 80% reduction in CO₂ emissions (versus 1990 levels) and an ecological footprint two-thirds of the national average. To achieve these goals, eco-towns are likely to run on nearly 100% renewable energy for heat, cooling and electrical demand and at least 50% on-site renewables “should be possible” [14].

Initially twelve eco-town developments were put forward for consideration and this paper considers one of those proposals. The site is located in central England and our analysis has focused on one of the design phases, an area of 87 hectares intended to house 6500 people. An initial assessment of the proposal by government-commissioned consultants found that the site “might be a suitable location subject to meeting specific planning and design objectives” but more information was required particularly on the energy strategy for the site [15]. Since then, the developers have commissioned a study of alternative energy systems to address some of these concerns. The report examined a range of renewable supply scenarios including large-scale wind, microgeneration technologies for heat and electricity (micro-wind, solar PV, solar thermal, heat pumps) before proposing two feasible strategies, based on biomass district combined heat and power (CHP) systems with varying amounts of wind energy. The strategy therefore raises questions about the choice of specific biomass conversion technologies, the structure of the district heating network and the availability of the biomass material (both imports from surrounding regions and local supplies).

3. Model specification and input data

Here we present a brief review of existing urban biomass optimization models and the rationale for our current work. An overview of the model’s specification and key input parameters is also given.

3.1. Literature review

There has been a large number of energy-systems models published in the last few decades. As many do not specifically account for biomass, we restrict our literature review to specific biomass models and refer to the recent review of Connolly et al. [16] for a comprehensive assessment of the generic energy-systems models and tools available.

Sokhansanj et al. [17] presented a supply-chain simulation model for the supply of agricultural biomass to a biorefinery. Although the model considers collection, storage and transport processes in great detail, the ultimate conversion of biomass to energy is not within the scope of their paper.

Frombo et al. [18] recently presented a model for optimizing the use of biomass for energy production. For a given area, divided into a number of locations and forest “parcels”, the model determines what type and size of plant to place at each location and which parcels will provide biomass for each plant. As the model is intended to be used for long-term planning, only annual energy demands are considered. Although the model considers many details of the harvesting and processing of the biomass before arriving at the plants, there are a number of limitations with their model. These are that: the model is formulated as an MINLP (mixed-integer non-linear program), which restricts the size of problem that can be tackled due to the difficulty in solving such models; only one plant is allowed per location, which may not be the optimal solution; and the model only considers thermal demand, with excess heat production being converted to electricity and sold to the

grid.

Another recent publication is that of van Dyken et al. [19], who developed an MILP model for biomass supply chains. This is essentially an extension of the eTransport model of the same group [20] in order to model the additional properties required to characterize the biomass. These properties (moisture content, density and heating value) can then be related to the various operations in the supply chain: storage, drying, transport etc. A feature of the model is that when two biomass streams are combined, they must have the same properties. The eTransport model decomposes the problem into an operational model (using MILP) and an investment model (using dynamic programming); the operational model determines the cost-optimal provision of predefined energy demands for a *given* infrastructure and set of technologies, as determined by the investment model.

The main differences between the previous work and our model are that: many models are developed specifically for a given purpose (e.g. biomass supply chains, in this case) whereas our model was designed from the outset to be completely generic (and hence easily extensible); we also aim to determine the optimal network, locations and types of conversion technologies and their operation simultaneously rather than assuming some of these features are exogenously specified.

3.2. Model specification

The model is based on the State-Task Network (STN) of Kondili et al. [21], which was used to represent generic recipes for batch-process scheduling. The STN is a directed graph where states represent any material with a given set of intensive properties and the tasks represent processes that convert a set of input states to a set of output states. A similar approach can be applied to urban energy systems, which can be represented as a resource-technology network (RTN). The resources represent any material or energy streams involved in the provision of energy (or other) services to a city. For

example, gas, electricity, heat, potable water, waste water, municipal solid waste and CO₂ would all be resources. The technologies represent any process that can convert a set of input resources to a set of output resources. A typical technology would be a CHP unit, which primarily produces high-quality heat, electricity and CO₂ from an input resource, such as natural gas. The high-quality heat may then be converted to space and water heat in buildings by using a heat exchanger connected to a district heating network.

Technologies are also used to represent storage and transport of resources. This approach facilitates the modelling of resource requirements and losses when transporting or storing resources. For example, transporting gas along a pipeline requires resources to power the compressors and electricity is lost when stored in batteries for long durations or transported.

The RTN describes *how* services may be provided but the model must also consider *where* and *when* these processes take place. The description of the energy system is therefore incomplete without a spatial description of the city and its service demands, as a function of time and space. Our model considers the city as a number of zones (of any shape and size), each of which has time-varying demands for services. The model will determine how best to satisfy these demands by specifying the location of the technologies and the transport infrastructure for each resource (e.g. electricity, gas etc.). The operation of each technology and the flows in the networks are also determined as a function of time.

Finally, unless the city is entirely self-sufficient, it will need to import some resources from other cities and surrounding hinterlands. Similarly any excess production of resources may be exported, subject to there being demand for them (this includes export of wastes, at a cost). Constraints may be used to limit the locations and quantities of any imports and exports.

The main constraint in the RTN model is the resource balance, which is shown in simplified form below.

$$P_{rit} + Q_{rit} + I_{rit} + S_{rit} - E_{rit} - D_{rit} = 0, \quad \forall rit, \quad (1)$$

where, for each resource r in zone i at time t , P_{rit} is the net production rate, Q_{rit} is the net inflow from all of the other zones (transportation), I_{rit} is the rate of import, S_{rit} is the net use of stored resource, E_{rit} the rate of export and D_{rit} is the demand. Whereas D_{rit} is a parameter (given as input), the other terms are decision variables that depend on which technologies are selected and their rates of utilization (e.g. if a CHP is chosen for zone i , then its rate at time t contributes to the values of P_{rit} for all r). The relationships are defined by technology-specific parameters such as maximum and minimum operating rates, coefficients of performance and so on.

The model's decision variables therefore include the locations of resource imports, exports, and network connections (all of which are binary variables); the number of technologies installed per cell (an integer variable); and the operating rates of the technologies, the amounts of resources in storage, and the flows within the networks (continuous variables). The objective function is to minimize the total annualized cost (capital, operating, and resource imports) of satisfying the resource demands. Since all of the constraints are linear, this results in a mixed-integer linear program (MILP). A full description of the model is currently in review [22].

3.3. Input data

The following is a summary of the major data inputs to the model.

3.3.1. Resource demands

The demands for heat and electricity are considered for average winter and summer days. The figures in Table 1 were estimated using UK benchmark data [23] and additional information provided by the developers.

3.3.2. Urban biomass fuels

The proposed modelling scenarios considered two biomass fuels: forestry residues and wood chips. Both fuels were assumed to be imported from nearby areas with no production from within the urban area. This is because a previous study found that local resources for this site would only be able to supply 1% of the overall requirement for biomass fuel [24]. Table 2 summarizes the properties of these materials.

3.3.3. Technology options

In the business-as-usual case, we assume that demands for heat and power are met by imported electricity and gas (converted to heat in domestic gas boilers). However, the options for the biomass scenarios are more complex. As shown in Figure 1, the conversion chain starts with imported forestry residues which are first converted to wood chips before being burned in domestic boilers or CHP units. A number of biomass energy conversion technologies have been identified as potentially suitable for the case study considered here, including domestic biomass boilers, CHP plants based on organic Rankine cycles (ORC), and CHP plants based on gasifiers coupled to internal combustion engines (ICE). The assumptions for each of these technologies are briefly described below.

Chippers

A 5 t/hr stationary chipping plant was considered, and the related investment, operating and maintenance costs estimated from Spinelli and Hartsough [25] and Spinelli and Visser [26].

Domestic boilers

In case of domestic boilers, a 25 kW_t standard chip boiler was considered, and the investment, operating and maintenance costs also include a small on-site storage facility and ash discharge costs. The technical parameters assumed in the simulation and the cost figures are estimates based

on Biomass Energy Centre [27], National Energy Foundation [28], Bergman and Jardine [29].

CHP plants

In the case of CHP plants, the resulting high-grade district heat is distributed to smaller heat exchangers throughout the city to meet final heat demand. Chip-fired ORC-CHP plants are one of the most common solutions for CHP production via solid biomass. Although this technology has a lower overall electrical efficiency compared to other options, its reliability and the possibility to generate large amounts of thermal energy for district heating make it attractive for this case study [30, 31, 32]. The option of gasifiers coupled to ICE is still at a demonstration stage but is considered here as it looks highly promising, in particular given the high energy conversion efficiency achievable at small sizes [33, 34].

A key question is what size of CHP unit to use. As the total demand for electricity is 1.5 MW, we have given the model the choice of three sizes: 0.5, 1.0 and 2.0 MW_e (corresponding respectively to 3, 5 and 10 MW_t in the ORC case and 1.5, 3 and 6 MW_t in the ICE case). In both CHP technologies, a fixed heat:electricity ratio was considered and chip-fired back-up boilers were integrated with CHP plants to cover the heat demand during winter (100–1000 kW_t), thus avoiding over-sizing of the plants. In fact, there is a trade-off between large back-up boilers, able to cover all the winter peak demand but operating for a short period, and small back up boilers, which require electricity to be converted into heat during peak demand periods. The range of operating hours for these CHP plants is 5,000–7,500 h/yr. No operating and maintenance costs have been considered for back-up boilers, since they are already included in the CHP plant operating costs.

Table 3 summarizes the main techno-economic parameters for the selected bioenergy technologies. The costs are calculated on an annualized turn-key basis, assuming a lifetime of 15 years and a discount rate of 6%

for the boilers and CHP plants, and 6 years at 6% for the chip production plant. The data refer to the net electrical efficiency and the costs include on-site biomass storage.

Storage and transportation

To complete the resource chain, technologies must also be introduced to store and move the biomass resources throughout the city. Storage is provided for wood chips only, using a closed system with a capacity of 20 kt and losses of 2%; assuming a 20 year lifecycle, we estimate the annualized capital cost to be £210 000 and the annual operating costs to be £48 000. For transport, a road network is assumed using trucks with a capacity of 20 m³ and a distance between biomass storage and energy conversion plants ranging between 1 and 10 km. We have also assumed that resource distribution networks will follow the proposed road network for the site. This data is summarized in Table 4.

Table 5 provides the other techno-economic parameters used in the model.

3.4. Model scenarios

We have studied five scenarios. In each model scenario, a subset of the technologies described above is used to illustrate different optimized energy supply options for the eco-town. In the biomass cases, all associated resource supply chain technologies are available: e.g. the model can choose to import finished wood chips directly or it can import forestry residues and convert them to chips using a chip-production facility. The scenarios are:

1. *Grid fuels.* This business-as-usual scenario provides a baseline for the biomass scenarios. Heat and power demands are assumed to be met by imported gas and electricity; small-scale domestic gas boilers are used to convert the gas into heat.
2. *Biomass boilers.* The second scenario also uses small-scale boilers, but fired by wood chips instead of mains gas. The optimization may choose

to import forestry residues and convert them to wood chips, to import wood chips directly or to use a combination of imports.

3. *Biomass CHP – ICE*. In this scenario, directly imported wood chips or converted forestry residues are used in a gasifier resource chain, converting biomass into syngas which is then burned in an internal combustion gas engine; heat is distributed via a district heat network. Electricity is also produced, reducing the site’s need for imported mains electricity.
4. *Biomass CHP – ORC*. This scenario examines the use of CHP plants based on an organic Rankine cycle, where the chips are combusted directly in a boiler and the vapourized working fluid is then expanded in a turbine to generate electricity.
5. *All technologies*. Finally we enable the model to use any combination of the technologies identified above.

As the most complicated scenario, the *All technologies* model provides a good indication of the overall problem size and it has 67508 single variables, 28120 discrete variables, and 156254 single equations. In contrast, the simpler *Grid fuels* scenario has 123053 equations and a total of 76203 variables.

In our analysis, we have focused on these scenarios in order to determine which general technology options look most promising. For a detailed design problem, the method should be extended with a sensitivity analysis, for example to assess how the results change in response to variations in biomass feedstock prices. Saltelli et al. [35] describe appropriate methodologies for such an analysis.

3.5. Objective function

In each scenario, the model was run with the aim of finding the energy system that minimizes the annual cost. This includes the cost of imported fuels, conversion, storage and transportation technologies (both annualized

capital costs and annual operating costs). The model is therefore pursuing a single objective, as we are exploring this problem from the perspective of the site developer, although a multiple objective formulation (such as the trade-offs between carbon and cost minimization) is a promising area for further investigation.

The costs of biomass energy systems can be reduced by policy incentives.¹ In the UK, there are three policies of primary interest: the Renewables Obligation (RO), the Climate Change Levy (CCL) and the European Emissions Trading Scheme (ETS). However, as the CCL and ETS target large energy users and the eco-town consists of multiple small consumers, we will focus only on the RO.

The Renewables Obligation aims to ensure that 10% of UK electricity will be supplied from renewable sources by 2010, by obliging electricity suppliers to provide a given percentage of their electricity from renewables. Initially, the Obligation was designed to favour the most profitable forms of renewable electricity by not discriminating between different forms of renewable generation and thereby letting the market decide which renewables to install. Since 1 April 2009, however, the Obligation has been “banded” so that forms of renewable generation that are more economically viable at present (e.g. co-firing, onshore wind) receive fewer ROCs than other less competitive generation technologies (e.g. offshore wind, microgeneration, biomass from dedicated crops).

In light of these policies, we have assumed that electricity produced by the biomass technologies studied here will receive payments of £108.74/MWh, thus reducing the value of the objective function. This is based on “dedicated biomass with CHP” technology which is eligible for 2 ROC/MWh and a 2008/9 ROC price of £54.37/ROC [39].

¹For a detailed overview of the UK bio-energy policy, see Defra [36], RCEP [37], Slade et al. [38].

4. Results

The performance of each scenario can be evaluated using several metrics. First, the annual costs of constructing and fueling the designed energy system (including distribution networks, capital investments and fuels) are calculated, both with and without the ROC value. Second, we consider the total energy consumption of the eco-town in both primary and final energy terms [assuming that the primary conversion efficiency of the UK's electricity grid is 38.7%, 40]. Third, we estimate the environmental impacts of each scenario including greenhouse gas and local air pollutant emissions.

A detailed assessment of each scenario's carbon footprint is beyond the scope of this research as the emissions profiles of wood chips and forestry residues are strongly affected by features such as the configuration of the supply chain (e.g. transport distances) and lifecycle impacts of building and decommissioning plants. Instead we use a range of likely values, assuming that the lifecycle emissions of imported wood chips are 22–28 kg CO₂/t [41]. Emissions values for electricity and natural gas are taken from Defra [42]. (Forestry residues are not used in any of the solutions.)

Determining the local air pollution (PM₁₀ and NO_x) impacts of biomass fuels is also difficult, owing to differences in biofuel, burner and abatement technologies, load patterns, local meteorological and topographic conditions. We again use a range of indicative values, shown in Table 6, and report output-weighted emissions averages. Rather than increasing the emissions based on partial load factors, we assume that the capacity factors shown in the summary table below represent the average running time of each technology. In other words, a technology running at 10% is assumed to run at its design load for 10% of the year, rather than at 10% load for the whole year.

4.1. Summary

Table 7 summarizes the results of each solution, including the number of technologies used, their operating performance and the solution quality.

The solutions for each of the household-scale technology scenarios (1 and 2) are quite similar. Both use 3132 domestic boilers to meet heat demand, that is approximately one boiler per household. However the boilers only run at an annual average load of 5% maximum capacity. This is due to the high-efficiency of the buildings and the model's aggregation of large time periods. Running the model at a finer temporal resolution would identify the extent to which these technologies are oversized or do in fact service short-term peaks in load. Both of these scenarios also feature similar resource-conversion chains, importing the required electricity and heating fuels (gas and wood chips respectively) directly from the national grid. In the biomass-boiler case, the model could have chosen to import forestry residues and convert them to wood chips within the eco-town; however, the results show that, because of their higher energy density, finished wood chips are directly imported instead. This is also true of the other biomass scenarios.

In the CHP cases (scenarios 3 and 4), a mix of technology sizes are chosen with one 5 MW CHP unit in the ICE case and a 1 MW plus a 3 MW CHP in the ORC case. The solutions also use a number of gas boilers, primarily in order to tackle the winter heat demand (for example, in the biomass ICE scenario, the summer average rate of the gas boilers was 21%, whereas in winter it was 86%).

In the all-technologies scenario (5), the model uses a combination of technologies but essentially relies on small and medium ICE CHPs with a few domestic wood chip and gas boilers to service heat demands far from the town centre.

The fuel consumption of each case is shown in Figure 2. Figure 3 shows how the resources are transported throughout the city for the all-technologies

scenario (5). Here, wood chips are imported into the centre of the site and then distributed to two CHP facilities in the north-east and south-west corners. These CHPs then provide district heat for the local area as well as electricity to supplement imports from the grid. A small gas import is required to top up the heat requirements in one area.

4.2. Costs

The objective of each optimization was to minimize the overall energy-system cost, consisting of capital costs, fuel costs and any ROC benefits achieved by generating renewable electricity from biomass. Figure 4 compares the cost of each scenario. Clearly biomass domestic boilers by themselves are a more expensive option than the traditional gas-fired systems. In contrast, biomass CHP systems offer significant cost savings of up to 15% over the gas-fired boiler scenario, especially when considering the income from Renewables Obligation Certificates. However, the cost balance is different because each CHP unit has to have an associated backup boiler (a constraint in the model). This increases the capital costs of the systems by 33% in comparison with individual gas boilers. The total system cost is similar though, because the units produce heat and power from comparatively cheap biomass fuels and receive revenue from the sale of ROCs. Nevertheless, higher upfront costs may be off-putting for some system developers.

4.3. Energy efficiency

The energy efficiency of each scenario can be evaluated by considering the primary energy requirements per capita, recalling that the end-service demands are the same in each scenario. Figure 5 shows that, as expected, the combined heat and power scenarios are the most energy efficient as they make full use of the biomass fuel. It is interesting to note however that the ICE scenario (3) relies on importing gas to top up demands, whereas the ORC scenario (4) imports electricity (because of its higher heat/electricity

output ratio in comparison to the ICE technology), resulting in a slightly lower overall energy efficiency. Compared to the business-as-usual gas boiler scenario, these CHP scenarios consume 15% and 19% less energy per capita respectively.

4.4. Environmental impacts

Figure 6 shows the average greenhouse gas emissions per capita in each scenario. The biomass CHP situations have much lower emissions, representing 87% and 80% reductions over the gas boiler case respectively. The all-technologies case has the lowest emissions, though, being 92% lower than the gas boiler case. These levels easily meet the eco-town proposed standard of an 80% CO₂ reduction.

As noted above, a full assessment of the local air pollution impacts for each scenario is not possible here. However, the indicative results suggest that the biomass scenarios do not necessarily result in undue increases in local air pollution. Only the case with domestic biomass boilers produces notably higher PM₁₀ emissions and NO_x emissions are lower in all biomass cases, particularly when using CHP systems. However, full modelling of local conditions would be required to assess whether the distribution of these impacts may be undesirable (e.g. if the CHP plants was sited next to a school or hospital).

5. Discussion and conclusions

This paper set out to examine bioenergy options for an eco-town development in the UK. Using a mixed-integer linear programming model which considers the full energy supply chain within the city, the results indicate that biomass energy offers significant promise for delivering low carbon urban developments. As noted above, these results are based on best estimates of parameter values and before committing to a specific system specification, a detailed sensitivity analysis would be beneficial.

The analysis raised a few key issues. First, the urban biomass solutions identified here all favoured the importation of high energy-density finished biofuels, such as wood chips. This implies that these fuels can be produced outside the urban area to take advantage of economies of scale, resulting in much higher efficiencies. The alternative, importing lower quality fuels into the urban environment for conversion in situ, would result in significant transportation costs and additional processing on-site. The results also implied that supply chains would be able to deliver these fuels reliably, as the model chose not to provide bulk urban wood chip storage in any of the scenarios.

Second, the Renewables Obligation has a small but notable effect on the cost of urban biomass energy systems. In the all-technologies case, for example, the income from ROCs was equivalent to a 5% saving on the total system cost. However, biomass energy systems have notably higher capital costs, due to the cost of the equipment, distribution networks and associated backup boilers. The question is how investment and ownership models can be created that enable the construction of these more-efficient systems without the obstacle of high upfront costs.

Third, the environmental impacts of these solutions — both in terms of global climate change and local air pollution — are difficult to estimate for urban biomass energy systems. Alternative biofuel processing routes can lead to significantly different lifecycle impacts and the location of biofuel technologies within the urban environment means that a full assessment of their impacts must be sensitive to the peculiarities of local geography and meteorology. Nevertheless, the results indicated that biomass offers significant carbon savings with acceptable levels of urban air pollution when compared to a gas boiler reference case.

Finally the current model optimizes for minimum cost. These costs include the capital costs of resource distribution networks and conversion

technologies, as well as the costs of the imported fuels. However, it would be interesting to modify the model to use a multi-objective optimization framework so that the multiple trade-offs between cost, carbon and local air pollution could be addressed. Furthermore, although local biomass resources were not feasible for this case study, incorporating an economic model of local land prices could be valuable to identify opportunities for local biomass cultivation.

In conclusion, the model introduced in this paper provides a framework for assessing the strategic options surrounding the use of biomass heat and power systems within an urban environment. It enables a range of transportation, conversion and storage technologies to be simultaneously evaluated thus facilitating strategic assessments of biomass supply options. Both this integrated methodology and its application to the eco-town case study are new to the existing biomass energy systems literature. However detailed assessments of both system design and impacts will be beneficial when seeking to move a project from the drawing board into reality.

Acknowledgments

The financial support of BP via the Urban Energy Systems project at Imperial College London is gratefully acknowledged.

References

- [1] IEA, . World energy outlook. Tech. Rep.; International Energy Agency; 2008.
- [2] EC, . Proposal for a directive of the European Parliament and of the Council on the promotion of the use of energy from renewable sources. 2008. URL http://ec.europa.eu/energy/climate_actions/doc/2008_res_directive_en.pdf.

- [3] DCLG, . Code for Sustainable Homes: Technical Guide. Tech. Rep.; Dept. of Communities and Local Government; 2009. URL http://www.planningportal.gov.uk/uploads/code_for_sustainable_homes_techguide.pdf
- [4] Pantaleo, A., Jablonski, S., Panoutsou, C., Bauen, A.. Assessment of the potential bioenergy demand for electricity and CHP: the case of the UK. In: 15th European Biomass Conference and Exhibition. Berlin; 2007, p. 1–15.
- [5] Greene, N., Hammerschlag, R.. Small and clean is beautiful: Exploring the emissions of distributed generation and pollution prevention policies. *The Electricity Journal* 2000;13(5):50–60.
- [6] Strachan, N., Farrell, A.. Emissions from distributed vs. centralized generation: The importance of system performance. *Energy Policy* 2006;34(17):2677–2689.
- [7] Genon, G., Torchio, M., Poggio, A., Poggio, M.. Energy and environmental assessment of small district heating systems: Global and local effects in two case-studies. *Energy Conversion and Management* 2009;50(3):522–529.
- [8] Jonsson, A., Hillring, B.. Planning for increased bioenergy use: Evaluating the impact on local air quality. *Biomass and Bioenergy* 2006;30(6):543–554.
- [9] Cundiff, J., Dias, N., Sherali, H.. A linear programming approach for designing a herbaceous biomass delivery system. *Bioresource Technology* 1997;59(1):45–55.
- [10] Gunnarsson, H., Rönnqvist, M., Lundgren, J.. Supply chain modelling of forest fuel. *European Journal of Operational Research* 2004;158(1):103–123.

- [11] Celli, G., Ghiani, E., Mocci, S., Pilo, F.. A multiobjective evolutionary algorithm for the sizing and siting of distributed generation. *IEEE Transactions on Power Systems* 2005;20(2):750–757.
- [12] Reche-López, P., Ruiz-Reyes, N., Galán, S.G., Jurado, F.. Comparison of metaheuristic techniques to determine optimal placement of biomass power plants. *Energy Conversion and Management* 2009;In Press, Corrected Proof.
- [13] Burton, J., Hubacek, K.. Is small beautiful? A multicriteria assessment of small-scale energy technology applications in local governments. *Energy Policy* 2007;35(12):6402–6412.
- [14] CABA, , Bioregional, . What makes an eco-town? A report from BioRegional and CABA inspired by the eco-towns challenge panel. Tech. Rep.; Commission for Architecture and the Built Environment; 2008.
- [15] DCLG, . Sustainability appraisal and habitats regulations assessment of the draft planning policy statement and the eco-towns programme. Tech. Rep.; Dept. of Communities and Local Government; 2008. URL <http://www.communities.gov.uk/planningandbuilding/planning/planningpolicyguidance>
- [16] Connolly, D., Lund, H., Mathiesen, B., Leathy, M.. A review of computer tools for analysing the intergration of renewable energy into various energy systems. *Applied Energy* 2010;87(4):1059–1082.
- [17] Sokhansanj, S., Kumar, A., Turhollow, A.F.. Development and implementation of integrated biomass supply analysis and logistics model (IBSAL). *Biomass and Bioenergy* 2006;30:838–847. doi: 10.1016/j.biombioe.2006.04.004.
- [18] Frombo, F., Minciardi, R., Robba, M., Sacile, R.. A decision support system for planning biomass-based energy production. *Energy* 2009;34:362–369. doi:10.1016/j.energy.2008.10.012.

- [19] van Dyken, S., Bakken, B.H., Skjelbred, H.I.. Linear mixed-integer models for biomass supply chains with transport, storage and processing. *Energy* 2010;35:1338–1350. doi:10.1016/j.energy.2009.11.017.
- [20] Bakken, B.H., Skjelbred, H.I., Wolfgang, O.. eTransport: Investment planning in energy supply systems with multiple energy carriers. *Energy* 2007;32:1676–1689. doi:10.1016/j.energy.2007.01.003.
- [21] Kondili, E., Pantelides, C.C., Sargent, R.W.H.. A general algorithm for short-term scheduling of batch operations—I. MILP formulation. *Computers & Chemical Engineering* 1993;17:211–227.
- [22] Samsatli, N., Keirstead, J., Shah, N.. A generic MILP model for the design of urban energy systems. *Energy Conversion and Management* submitted;.
- [23] Chartered Institution of Building Services Engineers, U.. *Cibse Guide F: Energy efficiency in buildings*. 2004.
- [24] Keirstead, J., Samsatli, N., Pantaleo, A.M., Shah, N.. Evaluating integrated urban biomass strategies for a UK eco-town. In: *Proceedings of the 17th European Biomass Conference*. Hamburg; 2009, p. 2115–2127.
- [25] Spinelli, R., Hartsough, B.. A survey of Italian chipping operations. *Biomass and Bioenergy* 2001;21(6):433–444.
- [26] Spinelli, R., Visser, R.. Analyzing and estimating delays in wood chipping operations. *Biomass and Bioenergy* 2009;33(3):429–433.
- [27] Biomass Energy Centre, . Biomass energy centre: Welcome. 2010. Accessed 11 May 2010; URL <http://www.biomassenergycentre.org.uk>.

- [28] National Energy Foundation, . The log pile website. 2010. Accessed 11 May 2010; URL <http://www.nef.org.uk/logpile>.
- [29] Bergman, N., Jardine, C.. Power from the people: Domestic microgeneration and the Low Carbon Buildings Programme. Tech. Rep.; Environmental Change Institute, Oxford; 2009. URL <http://www.eci.ox.ac.uk/publications/downloads/bergmanjardine09powerpeople.pdf>.
- [30] Bini, R., Duvia, A., Schwarz, A., Gaia, M., Bertuzzi, P., Righini, W.. Operational results of the first biomass CHP plant in Italy based on an organic rankine cycle turbogenerator and overview of a number of plants in operation in the EU since 1998. In: Proceedings of the 2nd World Biomass Conference for Energy Industry and Climate Protection. Rome; 2004, p. 1716–1721.
- [31] Obernberger, I., Carlsen, H., Biedermann, F.. State of the art and future developments regarding small scale biomass CHP systems with a special focus on ORC and Stirling engine technologies. In: Proceedings of the International Nordic Conference on Bioenergy. 2003, p. 1–7.
- [32] Turboden, . ORC turbogenerators for clean energy production. 2009. Access 18 November 2009; URL <http://www.turboden.eu/en/home/index.php>.
- [33] Knoef, H., editor. Handbook on Biomass Gasification. Enschede: Biomass Technology Group; 2005. URL <http://www.btgworld.com/index.php?id=91>.
- [34] Kirubakaran, V., Sivaramakrishnan, V., Nalini, R., Sekar, T., Premalatha, M., Subramanian, P.. A review on gasification of biomass. Renewable and Sustainable Energy Reviews 2009;13(1):179–186. doi:10.1016/j.rser.2007.07.001. URL <http://dx.doi.org/10.1016/j.rser.2007.07.001>.

- [35] Saltelli, A., Ratto, M., Andres, T., Campolongo, F., Cariboni, J., Gatelli, D., et al. *Global Sensitivity Analysis: The Primer*. Wiley Blackwell; 2008.
- [36] Defra, . Biomass taskforce. Report to government. Tech. Rep.; Dept. for Environment, Food and Rural Affairs; 2005.
- [37] RCEP, . Biomass as a renewable energy source. Tech. Rep.; Royal Commission on Environmental Pollution; 2004.
- [38] Slade, R., Panoutsou, C., Bauen, A.. Reconciling bio-energy policy and delivery in the UK: will UK policy initiatives lead to increased deployment? *Biomass and Bioenergy* 2010;Forthcoming.
- [39] Ofgem, . Renewables obligation: Annual report 2008–2009. Tech. Rep.; Office for Gas and Electricity Markets; 2010.
- [40] DECC, . Digest of UK Energy Statistics. 2009. URL <http://www.decc.gov.uk/en/content/cms/statistics/publications/dukes/dukes.aspx>.
- [41] Elsayed, M., Matthews, R., Mortimer, N.. Carbon and energy balances for a range of biofuels options. 2003. Access 13 May 2010; URL <http://www.berr.gov.uk/files/file14925.pdf>.
- [42] Defra, . Guidelines to Defra’s GHG Conversion Factors. 2008. URL <http://www.defra.gov.uk/environment/business/reporting/pdf/ghg-cf-guidelines-an>
- [43] DTI, . Uk biomass strategy: Working paper 1 - economic analysis of biomass energy. Tech. Rep. URN 07/950; Dept. of Trade and Industry; London; 2007.
- [44] BERR, . Quarterly energy prices. 2009. Accessed 5 June 2009; URL <http://www.berr.gov.uk/energy/statistics/publications/prices/index.html>.

- [45] Francescato, V.. Combustione del legno e polveri fini (in Italian). 2007. Access 13 May 2010; URL http://www.kwb.at/at/images/stories/files/Emissioni_legno_impaginatoVF_AIEL.pdf.

Resource	Time period	
	Summer	Winter
Heat	3.4	4.4
Electricity	1.5	1.5

Table 1: Resource demands (MW).

Type	Moisture (% d.m.)	LHV (MJ/kg)	Energy density (MJ/m ³)	Supply cost (£/t)
Forestry residues	35	11.4	3.75	50
Wood chips	20	14.6	7.29	60

Table 2: Technical and economic data of selected bioenergy resources [43]. LHV = lower heating value.

Technology	Size	η_e	η_t	TKC (k£)	O&M (k£/yr)
Chipping plant	5 t/hr	—	—	250	37.5
Domestic boiler	25 kW _t	—	82%	6	0.5
ORC-small	500 kW _e	18%	78%	2000	80
ORC-medium	1000 kW _e	19.5%	78%	3400	120
ORC-large	2000 kW _e	20%	78%	6400	220
ICE-small	500 kW _e	24%	50%	1750	75
ICE-medium	1000 kW _e	25%	50%	3000	140
ICE-large	2000 kW _e	26%	50%	6000	260
Back up boiler	100–1000 kW _t	—	85%	20–100	—

Table 3: Major techno-economic parameters for the selected bioenergy technologies. (η_e and η_t are electrical and total efficiencies respectively; TKC = turn key cost)

Resource	Cost (£/t·km)	Fuel requirements (MJ/t·km)
Forestry residues	0.36	1.7
Wood chips	0.24	1.1

Table 4: Biomass transport parameters (assuming short-distance transport via road and diesel consumption of 0.35 kg/km)

		Value
<i>Resources</i>		
Electricity import cost [44]		7.86 p/kWh
<i>Networks</i>		
Electricity network cost		£80 000/km
Gas network cost		£150 000/km
District heat network cost		£350 000/km
<i>Technologies</i>		
Gas boiler	Max capacity	25 kW
	Unit cost	£1000
	Ann. op. cost	£60
Heat exchanger	Max capacity	30 kW
	Unit cost	£300
	Ann. op. cost	£50

Table 5: Other techno-economic parameters.

Technology	PM ₁₀ ($\mu\text{g}/\text{Nm}^3$)	NO _x ($\mu\text{g}/\text{Nm}^3$)
Gas boilers	5	300–400
Domestic biomass boiler and back-up boiler	30–50	300–400
ORC	10–30	200–300
ICE	10–30	200–300

Table 6: Average air emission level ranges for the different scenarios under investigation [8, 45].

Metric	Scenario				
	1	2	3	4	5
<i>Headline metrics</i>					
Energy consumption (delivered, GJ/cap)	28.6	30.7	34.1	27.4	34.6
Energy consumption (primary, GJ/cap)	40.3	42.4	34.2	32.7	35.9
Greenhouse gas emissions (tCO ₂ /cap)	2.2	1.14–1.15	0.27–0.29	0.44–0.46	0.17–0.19
PM ₁₀ emissions ($\mu\text{g}/\text{Nm}^3$)	7.5	30–50	5.4–11.9	2.5–6.8	9.3–19.0
NO _x emissions ($\mu\text{g}/\text{Nm}^3$)	450–600	300–400	136–190	47–70	119–168
Total cost w/o ROCs (mil GBP)	6.7	9.0	6.6	6.4	6.0
Total cost w/ ROCs (mil GBP)	6.7	9.0	6.2	6.3	5.7
Solution gap (% from relaxed)	1.6	0.2	12.3	9.0	5.8
<i>Installed technologies – number</i>					
Gas boiler	3132	-	59	3	1
Biomass boiler	-	3132	-	-	45
Heat exchangers	-	-	3073	3128	3086
Chip production	-	-	-	-	-
Chip storage	-	-	-	-	-
1 MW ICE CHP	-	-	-	-	1
3 MW ICE CHP	-	-	-	-	1
5 MW ICE CHP	-	-	1	-	-
1 MW ORC CHP	-	-	-	1	-
3 MW ORC CHP	-	-	-	1	-
5 MW ORC CHP	-	-	-	-	-
0.1 MW backup	-	-	-	2	-
0.5 MW backup	-	-	1	-	2
1 MW backup	-	-	-	-	-
<i>Installed technologies – average rate (% of max capacity)</i>					
Gas boiler	5.0	-	53.7	47.7	31.4
Biomass boiler	-	5.0	-	-	71.0
Heat exchangers	-	-	3.1	4.1	3.0
Chip production	-	-	-	-	-
Chip storage	-	-	-	-	-
1 MW ICE CHP	-	-	-	-	100
3 MW ICE CHP	-	-	-	-	86.0
5 MW ICE CHP	-	-	75.5	-	-
1 MW ORC CHP	-	-	-	8.4	-
3 MW ORC CHP	-	-	-	92.1	-
5 MW ORC CHP	-	-	-	-	-
0.1 MW backup	-	-	-	39.9	-
0.5 MW backup	-	-	55.0	-	39.7
1 MW backup	-	-	-	-	-

Table 7: Summary of results. Scenarios 1 = grid fuels, 2 = biomass boilers, 3 = biomass CHP (ICE), 4 = biomass CHP (ORC), 5 = all technologies.

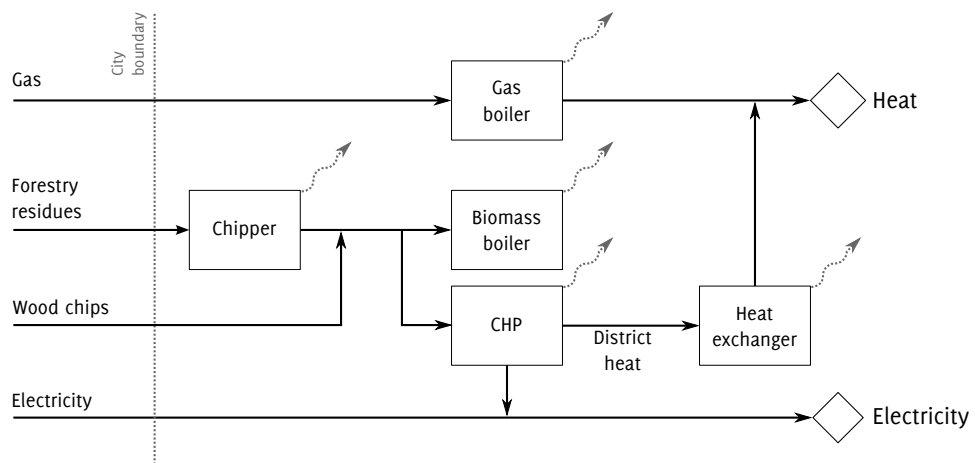

Figure 1: Schematic of a resource-technology network for an urban biomass energy system. Waste heat losses and CO₂ emissions from each conversion process are shown as wavy arrows.

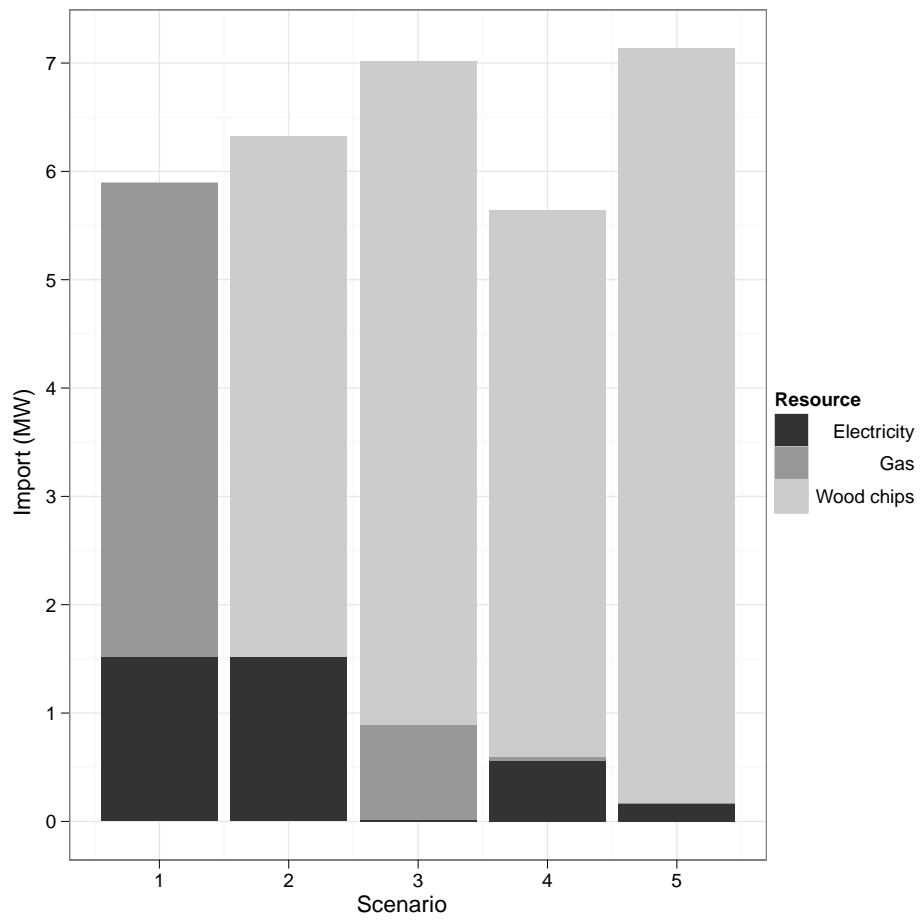
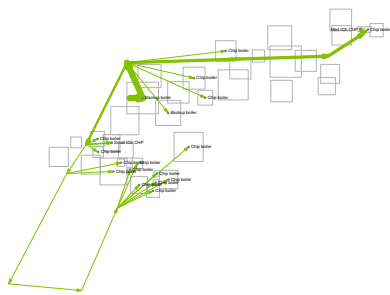
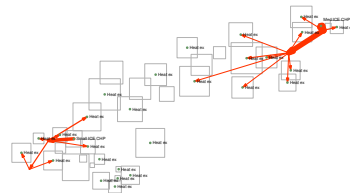

Figure 2: Imported fuels used to satisfy demands in each scenario.



(a) Wood chips



(b) District heat

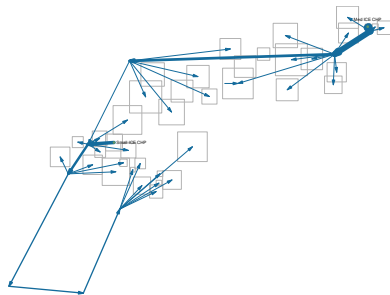

(c) Electricity

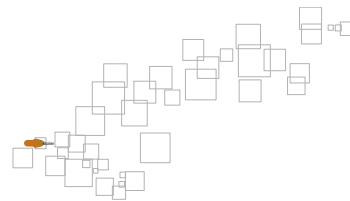

(d) Gas

Figure 3: Distribution networks for the winter period of the all-technologies scenario (5). Arrow widths are proportional to resource flows.

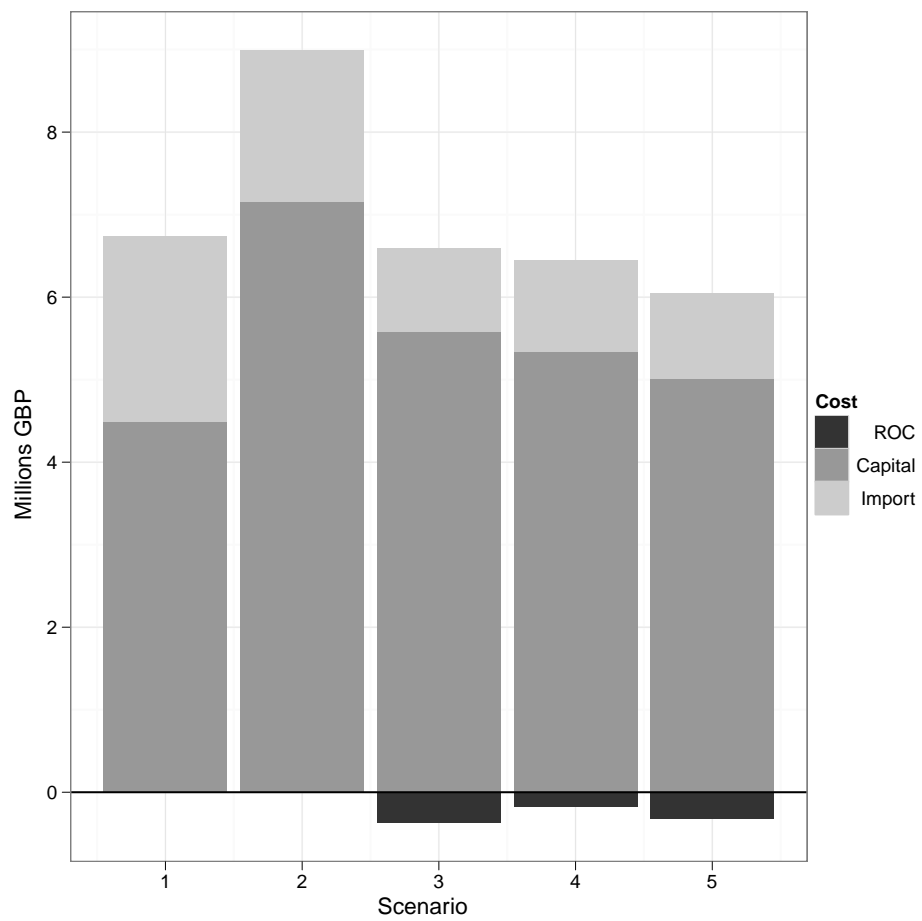

Figure 4: Costs of each scenario including any avoided costs achieved by savings from ROCs.

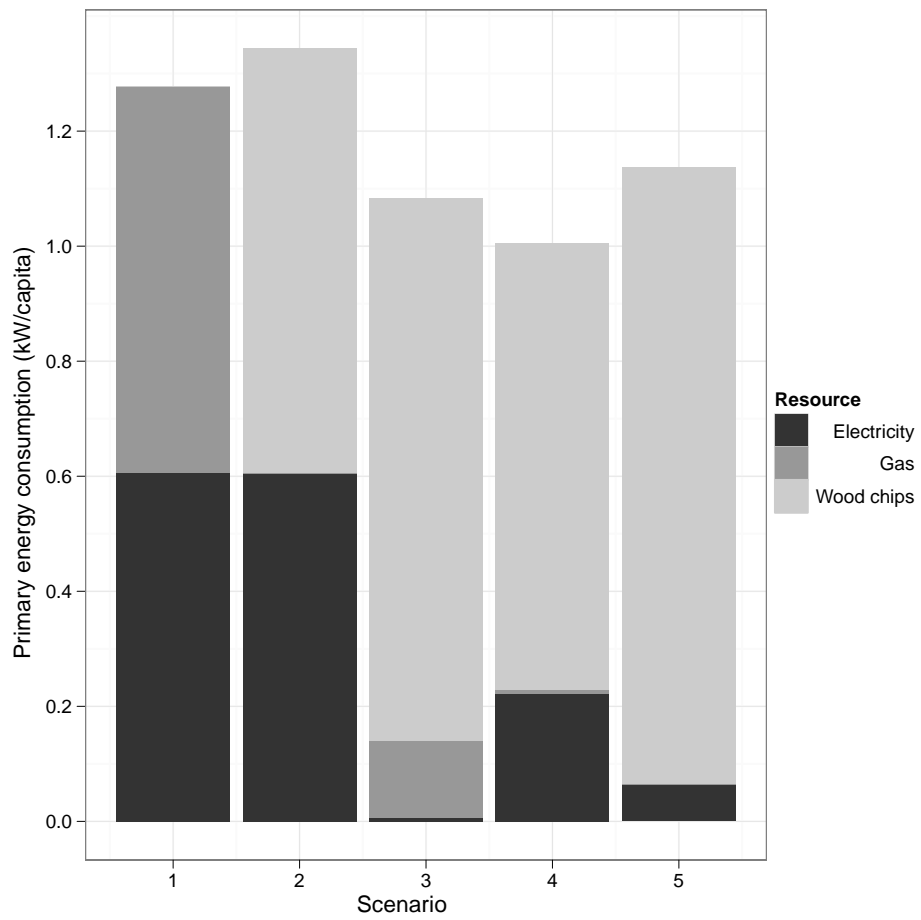

Figure 5: Per capita primary energy consumption by fuel.

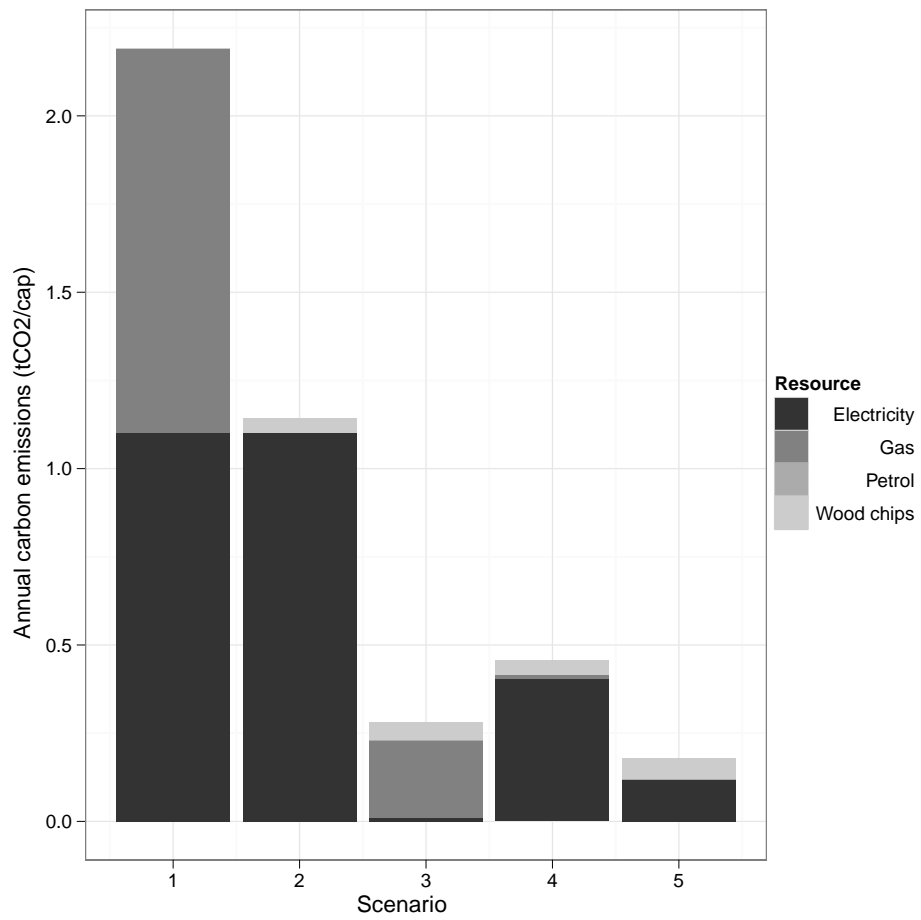

Figure 6: Annual per capita greenhouse gas emissions by fuel.